



CNC 8055 / CNC 8055i

**FAGOR** 

REF. 0307

(SOFT M: 7.xx)

(SOFT M: 7.1x)

**NEW FEATURES**



NEW FEATURES

(SOFT M: 7.XX)  
(SOFT M: 7.1X)

# INDEX

## Version 7.01

1	Detected errors .....	1
2	Sampling period .....	2
3	The meaningless zeros will not be displayed .....	2
4	Management of the new Sercos board .....	3
5	Key inhibiting codes for the monitors .....	3
6	New work languages .....	3
7	Load version without using an external microprocessor. ....	3
8	WINDNC improvements .....	4
9	Telediagnosis .....	4
10	Improvements to the profile editor .....	6
11	Modified variables .....	6
12	New variables .....	7
13	New range of OEM subroutines. ....	9
14	RPT instruction with program number definition .....	9
15	Improved non-random tool magazine management .....	9
16	Improved drive parameter management .....	10
17	User and OEM arithmetic parameters .....	10
18	Exponential type of leadscrew backlash peak .....	10
19	Functions associated to machine safety .....	11
19.1	Limit the feedrate of the axes and the spindle speed .....	11
19.2	Cycle Start disabled by hardware errors .....	12
19.3	Maximum spindle machining speed. ....	12
20	Axes (2) controlled by a drive .....	13
21	Mandatory home search .....	13
22	Change of active tool from the PLC .....	14
23	Synchronize a PLC axis with a CNC axis .....	14
24	Error register .....	15
25	Path JOG mode .....	15
26	Tool inspection .....	17
27	New instructions in the configuration language .....	17
28	Improvements in tool compensation .....	18
29	Improvements in high speed machining .....	19
30	New graphics option .....	20
31	Improvement in the tool measuring cycle PROBE1 .....	20
31.1	Measure or calibrate the tool length. ....	21
31.2	Measure or calibrate the radius of a tool. ....	23
31.3	Measure or calibrate the tool radius and length. ....	24
32	Oscilloscope function .....	26
32.1	Configuration .....	27
32.2	Scale / Offsets .....	32
32.3	Analysis .....	33
32.4	Parameters .....	33
32.5	Actions .....	34
32.6	Begin .....	34
33	MC model. Execute a part-program .....	35
34	MC model. Maintain F, S y Smax on power up .....	35
35	MC model. Messages and warnings .....	35
36	MC model. Tool calibration .....	35
37	MC model. Cycle selection .....	36
38	MC model. Auxiliary M functions in all the cycles .....	37
39	MC model. Modifications in the tapping cycle .....	38
40	MC model. Modifications in the Multiple milling and positioning cycles .....	38
41	MC model. Icon indicating the available options .....	38
42	MC model. Tool measurement and calibration .....	39

**Version 7.11**

---

1	Detected errors .....	43
2	New validation codes .....	46
3	Smooth stop in probing move (G75/G76) .....	46
4	Square-corner or round-corner machining when changing tool offset .....	46
5	New management of the distance-coded reference mark (I0) .....	47
6	Improved look ahead .....	47
7	Leadscrew error compensation in both directions .....	47
8	Parameters accessible from the oscilloscope or OEM subroutine .....	48
8.1	Axis parameters that may be modified from the oscilloscope .....	48
8.2	General parameters modifiable from the oscilloscope .....	48
8.3	Machine parameters modifiable from an OEM program .....	48



NEW FEATURES

## 1 Detected errors

### NBTOOL Variable

The installation and programming manuals indicate that this variable is read-only from the CNC, PLC and DNC.

Actually, it is read-only from the CNC and DNC and it can only be used inside a tool-change subroutine.

### OPMODE Variable

This variable also returns the following code:

25	Rapid simulation with S=0
56	User parameter table
57	OEM parameter table
117	Oscilloscope.

### Probe canned cycle for surface measurement (PROBE 3)

The moving direction with K1 is as shown in this figure.

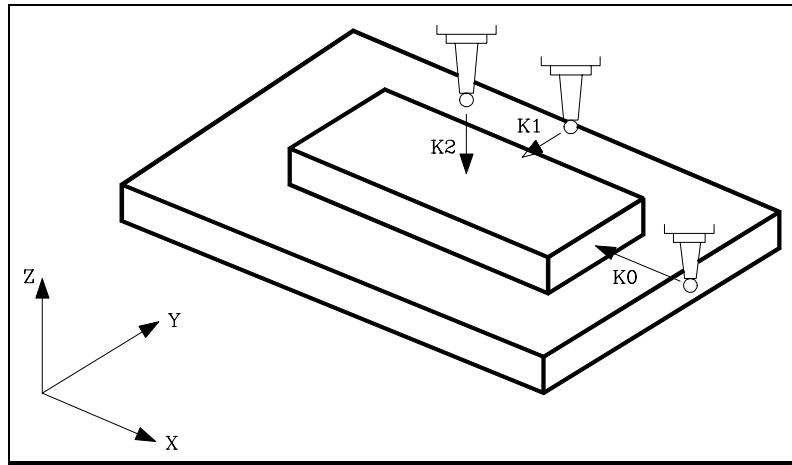

### Connection of the KS50/55 adapter:

The installation manual describes how to use this adapter, but the correct connection is the following:

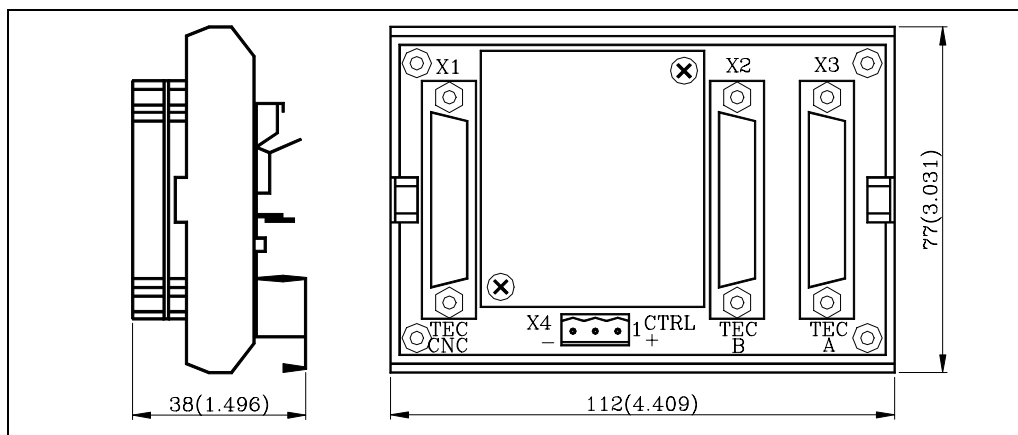

NEW FEATURES  
(SOFT M: 7.xx)

Detected errors

- X1** 25-pin female SUB-D type (normal density) connector to connect the "Central Unit + Monitor".
- X2** 25-pin female SUB-D type (normal density) connector to connect the "Alphanumeric keyboard + Monitor".
- X3** 25-pin female SUB-D type (normal density) connector to connect the "Operator panel".
- X4** 3-pin male Phoenix connector, 7,62 mm pitch, to select the keyboard to be attended by the Central Unit.

Pin	Value	Meaning
1	0V 24V	The CNC attends to the operator panel The CNC attends to the alphanumeric keyboard
2	----	Not being used
3	GND	External power supply

If connector X4 is not supplied with voltage, the CNC attends to the operator panel.

## Main plane simulation

Page 2 of chapter 3 of the operating manual does not mention this type of simulation.

It only executes the movements corresponding to the axes that form the main plane.

It takes into account the tool radius compensation (functions G41, G42) thus drawing the tool center path.

It sends the M, S, T functions to the PLC.

It starts the spindle, if programmed.

The axes move at maximum feedrate F0 regardless of the F that was programmed and it may be varied with the Feedrate Override switch.

## 2 Sampling period

From this version on, on the 8055/C and 8055i/C models that do not have the CPU turbo, it is possible to set a sampling period of 2 milliseconds g.m.p. "LOOPTIME (P72)".

The following values may be allocated to plc.m.p. "CPUTIME (P26) that sets the time the System CPU dedicates to the PLC when programming a "LOOPTIME = 2 ms":

CPUTIME = 0	1 ms every 8 samplings, every 16 ms
CPUTIME = 1	1 ms every 4 samplings, every 8 ms
CPUTIME = 2	1 ms every 2 samplings, every 4 ms

By default 0

## 3 The meaningless zeros will not be displayed

From this version on, the data displayed on the screen (positions, feedrates, etc.) will not display the meaningless zeros to the left of the value. Example:

From this version on	Z -4.210
Previous versions	Z -00004.210



NEW FEATURES

(SOFT M: 7.xx)

Sampling period

## 4 Management of the new Sercos board

This software version is ready to work with the new Sercos boards, reference: 902103 and newer.

The "Hardware diagnosis" function shows these boards as "SERCOS816" because they carry the SERCON 816 chip.

## 5 Key inhibiting codes for the monitors

The inhibiting codes for softkeys F1 through F7 of monitors models such as "NMON-55-11-LCD" are:

F1	F2	F3	F4	F5	F6	F7
Bit 24 R508	Bit 25 R508	Bit 26 R508	Bit 27 R508	Bit 28 R508	Bit 29 R508	Bit 30 R508

## 6 New work languages

Basque and Russian are now available from this version on.

**LANGUAGE (P122)** Defines the work language

Possible values:

0 English	1 Spanish	2 French
3 Italian	4 German	5 Dutch
6 Portuguese	7 Czech	8 Polish
9 Mainland Chinese	10 Basque	11 <i>Russian</i>

By default 0

## 7 Load version without using an external microprocessor.

This feature is available on the 8055i CNC models whose identification label shows "03a" or later and on 8055 CNC models whose CPU label shows "32a" or later. Besides, their software version must be V7.01 or later.

It is not necessary to turn the CNC off and back on or actuate the external switch to update the software version, as indicated in section 2.2 of the Operating Manual.

To update the CNC software, proceed as follows:

- Remove the "Memkey Card" and insert the "Memory Card" that contains the software version to be updated.
- Access the Diagnosis mode - Software Configuration and press the [Load version] softkey.

The CNC will show the software updating stages and their status.

- When done updating it, remove the "Memory Card" that contains the software version and insert the "Memkey Card" back.

- Note:**
- If the "[load version]" softkey is pressed but the Memory Card containing the software version is missing, the CNC will issue the relevant error message.
  - The CNC cannot execute anything if it has the Memory Card that contains the software version.



NEW FEATURES

(SOFT M: 7.xx)

Management of the  
new Sercos board

## 8 WINDNC improvements

From this CNC version on and having WINDNC version V2.0 and the following, it is possible:

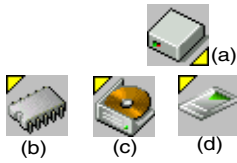

- Select the work unit for CNC files Option (a). Then indicate the desired work unit: Memory (b), Hard Disk (c) or Card A (d).
- From a PC, using the WINDNC application, copy from the CNC to the PC or vice versa, any file, program or table available in the CARDA or hard disk. The available new tables are:

OEP	OEM arithmetic parameters
USP	USER arithmetic parameters
DRS	Spindle drive table
DS2	Table of the Second Spindle drive
DPX	Table for the Auxiliary spindle drive
DRX, DRY,	Tables for axis drives
DRZ, DRU,	
DRV, DRW,	
DRA, DRB,	
DRC	

These tables are compatible with the tables that have been saved from the drive to a PC via serial line using WINDDS.

- Consult the table directory (machine parameters, zero offsets, magazine, tools, tool offsets, geometry, user parameter, OEM parameter, etc.).
- Read global and local arithmetic parameters individually using variables GUPn and LUP(a,b). The installation and programming manuals describe how to use these variables.
- Having telediagnosis, display CNC screens at the PC in remote mode via serial line or via MODEM.
- Having telediagnosis, dial the telephone number associated with the modem at the PC.

## 9 Telediagnosis

It may be used to govern and monitor the CNC status remotely through the RS232 serial line or using a modem through a telephone line.

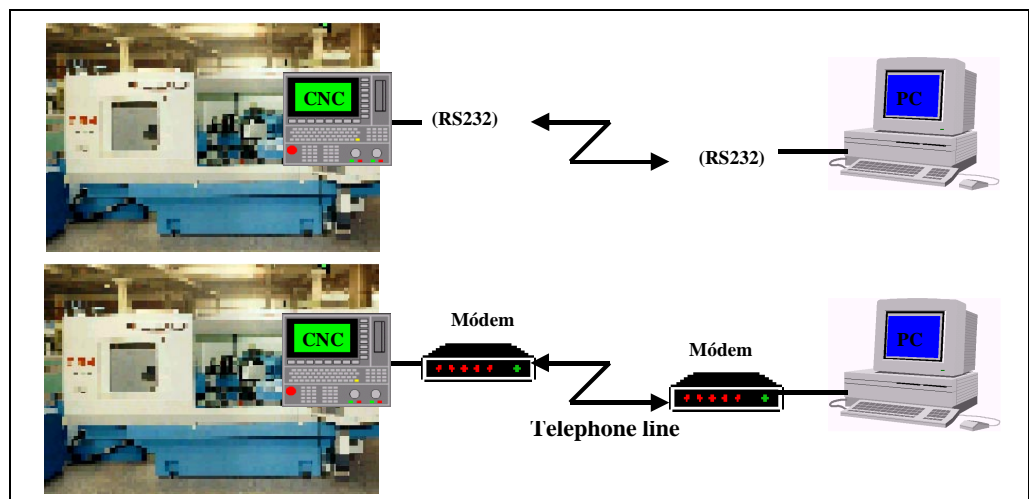

NEW FEATURES  
(SOFT M: 7.XX)

WINDNC  
improvements



The remote PC must have the WINDNC application version 2.00 or later installed in it and the CNC software version must be V07.01 or later.

### CNC connection to the telephone line

It must be done through the RS232 serial line and using a modem that has RS232 serial line communication.

First, turn on the modem, then the CNC and then the remote PC, in that order.

### PC connection to the telephone line



(a)

Connect the PC to the telephone line through a modem and execute the WINDNC application. Within the options for the serial line, select option (a).

The application shows the following window. Indicate which modem is being used and the telephone number to dial.

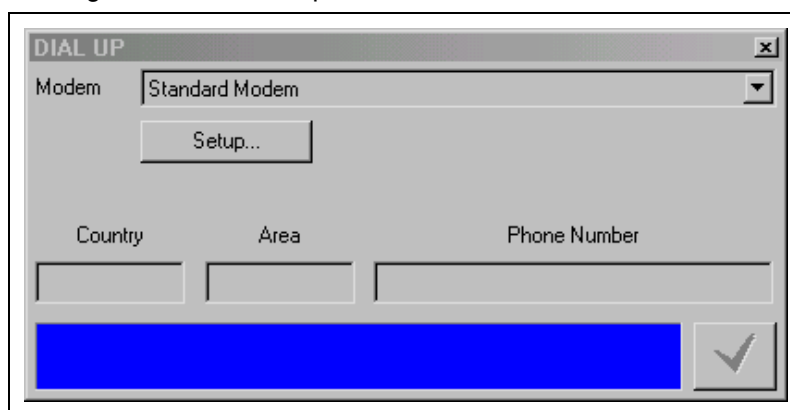

### PC-CNC communication (Telediagnosis)



(b)

Once the connection has been established (either via serial line or via modem), select the "telediagnosis" option (b) of the WINDNC application.

From this moment on, the CNC may be governed either from its own keyboard or remotely from the PC keyboard.

- The PC will display the same information (screens) as the CNC.
- It is possible to access the different CNC modes, modify tables and parameters when knowing the password, simulate programs, etc.
- For safety reasons, it is not possible to move the axes of the machine or execute part-programs.



(c)

With the WINDNC application, it is also possible to send to the CNC a file containing a keystroke sequence, option (c).

While in remote control mode, no other DNC command may be executed through the same serial line (for example the execution of an infinite program).



(d)

With option (d), it is possible to save into a BMP file a CNC screen image that is being displayed.

### End the communication (End telediagnosis)



(e)

To end the communication, select option (e) from those associated to the serial line in the WINDNC application.

## 10 Improvements to the profile editor

The following improvements have been made:

It is possible to select the coordinate system of the work plane, axes and their direction.

The right window, under "Display Area", indicates whether the autozoom is on or not and the selected coordinate system.

It includes graphic data editing. Use the up-arrow and down-arrow keys to select the desired window and key in the desired value.

It is possible to modify rectangular and circular elements.

There are 2 new softkeys:

Save and continue

To save a profile without having to quit the session.

Undo

To undo the last modification.

On conversational models, MC and MCO, it indicates the number of the profile being edited.

## 11 Modified variables

**HARCON** It indicates, with bits, the CNC's hardware configuration.

The bit will be "1" when the relevant configuration is available.

From now on, bits 24, 25, 26 indicate the type of monitor and bits 27, 28 the CPU turbo board being used.

bit		
26,25,24	000	Color LCD Monitor
	001	Monochrome LCD monitor
28,27	00	Turbo board at 25 Mhz
	01	Turbo board at 40 Mhz

**MPGn** These variables, related to machine parameters, that until now were read-only, from this version on, can be read and written from the CNC in the following cases:

**MP(X-C)n**

**MPSn**

**MPSSn**

**MPASn**

**MPLCn**

- When they are executed inside an OEM program.

- When they are executed inside an OEM subroutine.

To modify machine parameters from the PLC, an OEM subroutine containing the relevant variables must be executed using the CNCEX instruction.

In order for the CNC to assume the new values, one must operate according to the indicators associated with each machine parameter.

// It is necessary to press the keystroke sequence: "Shift - Reset" or turn the CNC off and back on.

/ Just press Reset.

The rest of the parameters (those unmarked) will be updated automatically, only by changing them.

## 12 New variables

### Feedrate related variables

**FREAL(X-C)** Actual (real) X-C axis feedrate Is read-only from the CNC, DNC and PLC.

**FTEO(X-C)** Theoretical X-C axis feedrate Is read-only from the CNC, DNC and PLC.

### Coordinate related variables

**DPLY(X-C)** "Coordinates of the selected axis" displayed on the screen Is read-only from the CNC, DNC and PLC.

**DRPO(X-C)** Position indicated by the X-C axis Sercos drive (Sercos variable PV51 or PV53 of the drive). Is read-only from the CNC, DNC and PLC.

**GPOS(X-C)n p** Programmed coordinate for a particular axis (X-C), in the indicated block (n) and program (p).

(P100 = GPOSX N99 P100)

It assigns to P100 the value of the coordinated programmed for the X axis in label N99 and located in program P100.

It Is read-only and it is only enabled at the CNC. Only programs located in RAM memory may be consulted.

- If the defined program number does not exist, it issues Error 69 "Program does not exist".
- If the defined block number does not exist, it issues error 1060 "undefined label".
- If the requested axis is not programmed in the indicated block, it returns the value: 100000.0000

### Spindle related variables

**DRPOS** Position indicated by the Sercos drive of the spindle. Is read-only from the CNC, DNC and PLC.

**SDRPOS** Position indicated by the Sercos drive of the second spindle. Is read-only from the CNC, DNC and PLC.

**FTEOS** Theoretical spindle turning speed. Is read-only from the CNC, DNC and PLC.

**SFTEOS** Theoretical second spindle turning speed. Is read-only from the CNC, DNC and PLC.

### Speed limit related variables

**MDISL** Maximum spindle machining speed. It is read-write from the PLC and read-only from DNC and CNC.

This variable is also updated with the programmed S value, in the following cases:

When programming "G92 S" in MDI mode



NEW FEATURES

(SOFT M: 7.xx)

New variables

When programming "G92 S" in ISO code in MC mode.

### Variables related to Probe cycles

- TIPPRB** It indicates the PROBE cycle being executed at the CNC. Is read-only from the CNC, DNC and PLC.
- TIPDIG** It indicates the DIGIT cycle being executed at the CNC. Is read-only from the CNC, DNC and PLC.

### PLC related variables

- PLCMM(n)** It permits reading modifying a single PLC mark (the PLCM variable permits reading or modifying 32 marks at once). It is read-write and it is only available from the CNC.

(PLCMM4 = 1)

It sets mark M4 to "1" and leaves the rest untouched

(PLCM4 = 1)

It sets mark M4 to "1" and the following 31 marks (M5, through M35) to "0"

### Feedback related variables

- ASIN(X-C)** "A" signal of the CNC sinusoidal feedback for the X-C axis. Is read-only from the CNC, DNC and PLC.
- BSIN(X-C)** "B" signal of the CNC sinusoidal feedback for the X-C axis. Is read-only from the CNC, DNC and PLC.
- ASINS** "A" signal of the CNC sinusoidal feedback for the spindle. Is read-only from the CNC, DNC and PLC.
- BSINS** "B" signal of the CNC sinusoidal feedback for the spindle. Is read-only from the CNC, DNC and PLC.
- SASINS** "A" signal of the CNC sinusoidal feedback for the second spindle. Is read-only from the CNC, DNC and PLC.
- SBSINS** "B" signal of the CNC sinusoidal feedback for the second spindle. Is read-only from the CNC, DNC and PLC.

### Variables related to the WGDRAW application

- PANEDI** Number of the screen created by the user or by the OEM using the WGDRAW application for diagnosis, consultation, work cycle, etc, that is being consulted. Is read-only from the CNC, DNC and PLC.
- DATEDI** Number of the screen element created using the WGDRAW application that is being consulted. Is read-only from the CNC, DNC and PLC.



NEW FEATURES

(SOFT M: 7.XX)

New variables

## 13 New range of OEM subroutines.

A new range of OEM subroutines has now been defined.

Available subroutine ranges:	
General subroutines	SUB 0001 - SUB 9999
OEM subroutines	SUB 10000 - SUB 20000

Although OEM subroutines are treated like the general ones, they have the following restrictions:

- They can only be defined in OEM programs, having the [O] attribute. Otherwise, it shows error 63 "Program subroutine number between 1 and 9999."
- If the subroutine to be executed using CALL, PCALL or MCALL is an OEM subroutine and it is located in a program that does not have the [O] attribute, it will issue Error 1255 "Subroutine restricted to OEM program".

## 14 RPT instruction with program number definition

From this version on, the RPT instruction can execute a portion of the same program or of the indicated program.

(RPT N(expression), N(expression), P(expression))

The new parameter "P" indicates the number of the program located in RAM memory containing the two blocks defined by the N labels.

- If parameter "P" is not defined, the CNC interprets that the portion to be repeated is located in the same program.
- If the defined program number does not exist, it issues Error 69 "Program does not exist".

### Warning:



*Since the RPT instruction does not interrupt block preparation or tool compensation, it may be used when using the EXEC instruction and while needing to maintain tool compensation active.*

## 15 Improved non-random tool magazine management

When the tool changer is configured as non-random, the tools must be placed in the tool magazine table in the pre-established order (P1 T1, P2 T2, P3 T3, P4 T4, etc.).

With this improvement, it is possible to assign several tools to each tool position.

**TOOLMATY (P164)** This g.m.p. is taken into account when using a non-random tool magazine. It indicates how many tools may be assigned to each turret position.

- 0 One tool per position
- 1 Several tools per position.

By default 0



NEW FEATURES

(SOFT M: 7.XX)

**New range of OEM subroutines.**



Bit 16 of g.m.p. "ACTBAKAN (P144)" indicates the backlash peak being used.

- 0 rectangular leadscrew backlash peak
- 1 exponential type of leadscrew backlash peak

By default 0

A finer tuning of the leadscrew backlash consists in testing the circle geometry and watch for internal peaks when changing quadrants (left figure). In these cases, it is recommended to set bit 15 of g.m.p. "ACTBAKAN (P144)" to "1" to eliminate the internal peaks.

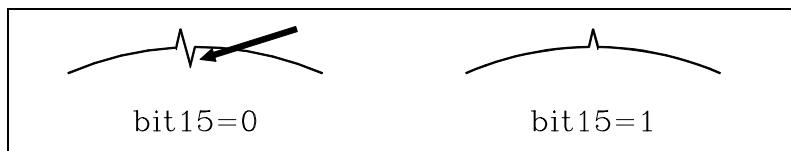

Under these conditions, the CNC eliminates the leadscrew backlash peak as soon as it detects a movement reversal. If the internal peaks are not eliminated, adjust the leadscrew backlash compensation better.

**ACTBAKAN (P144)** It has 16 bits counted from left to right.

bit	Function	bit	Function
1		9	
2		10	
3	Additional pulse with G2 / G3	11	
4		12	
5		13	
6		14	
7		15	It minimizes internal peaks detected with the circle geometry test
8		16	Exponential leadscrew backlash peak

By default, all bits are set to "0".

## 19 Functions associated to machine safety

### 19.1 Limit the feedrate of the axes and the spindle speed

It is possible to limit the feedrate of the axes and the spindle turning speed.

**FLIMIT (P75)** The a.m.p. "FLIMIT" sets the maximum feedrate for each axis and the s.m.p. "SLIMIT" sets the maximum turning speed for each spindle.

**FLIMITAC (M5058)** When the PLC sets this signal high, it limits the feedrate of all the axes. It does not let any feedrate to exceed the value set by the corresponding a.m.p. "FLIMIT (P75)".

**SLIMITAC (M5059)** When the PLC sets this signal high, it limits the speed of all the spindles. It does not let any feedrate to exceed the value set by the corresponding s.m.p. "SLIMIT (P66)".

The limitation is applied in all work modes, including the PLC channel. When the mark is high, the CNC applies the limitation and when going low, it restores the programmed F or S.



NEW FEATURES

(SOFT M: 7.xx)

Functions associated to machine safety

When the spindle moves with PLCCNTL, the spindle limitation is ignored.

## 19.2 Cycle Start disabled by hardware errors

If when pressing the Cycle-Start key, a hardware error is detected (Sercos board error, CAN board error, etc.), the CNC issues the corresponding error message and does not allow executing or simulating the program.

## 19.3 Maximum spindle machining speed.

To limit the spindle speed, use the MDISL variable associated with speed limits. It is read-write from the PLC and read-only from DNC and CNC.

This variable is also updated with the programmed S value, in the following cases:

- When programming "G92 S" in MDI mode
- When programming "G92 S" in ISO code in MC mode.
- In MC mode, when a new speed limit is defined in the "SMAX" field.

The speed limits entered via CNC, PLC (PLCSL) and DNC (DNCSL) keep the same functionality and priority unaffected by the new MDISL variable; in other words, the CNC keeps limiting the spindle speed like until now.

In order to comply with the safety regulation, it is recommended to manage from the PLC the variables associated with speed limits as shown in the following example:

- A new part-program cannot be executed without previously entering the speed limit. Otherwise, a message will be displayed.  
If the program is executed again, the limit does not have to be entered again, it is only required when executing the program for the first time.
- While executing a program if a new limit is entered in MDI, the new one will replace the previous one.
- In independent MC cycles it is not required to enter the SMAX because it is already defined in each cycle.
- If the program being executed already has a G92S, it will be validated only if it is smaller than the one programmed in MDI.
- When having two main spindles, the speed limit entered will be valid for both.

```

PRG
REA
(=CNCRD(OPMODA,R100,M1000) ; Reading of OPMODA
B0R100 AND INCYCLE = M100 ; Indicator of program in execution
;
DFU M100 ; At the beginning of the execution
= CNCRD(PRGN,R101,M1000) ; reads the program in execution
= CNCRD(MDISL,R102,M1000) ; and the S limitation from MDI
;
M100 ; During the execution
= CNCRD(PRGSL,R103,M1000) ; and the S limitation from CNC
;
M100 AND CPS R101 NE R201 ; If new program in execution
= M101 ; activates mark M101
;
M100 AND CPS R101 EQ R201 ; If same program in execution

```



NEW FEATURES

(SOFT M: 7.xx)

Functions  
associated to  
machine safety



```

= M102 ; activates mark M102
;
M101 ; If new program in execution
AND CPS R102 EQ 0 ; and the "S" has not been limited from MDI
= ERR10 ; Error 10: "The S has not been limited from
MDI"
;
M101 ; If new program in execution
AND CPS R102 NE 0 ; and the "S" has been limited from MDI
= MOV R101 R201 ; it copies the number of the program in
execution
= MOV R102 R202 ; and the S limitation from MDI
;
M102 ; If same program in execution
AND CPS R102 NE 0 ; and the "S" is limited again from MDI
= MOV R102 R202 ; it copies the S limitation from MDI
;
M100 ; If program in execution
AND CPS R202 LT R103 ; and "S" limitation from MDI < "S" limitation
from CNC
= CNCWR(R202,PLCSL,M1000) ; Applies "S" limitation from the PLC with the
value set in MDI
;
M100 ; If program in execution
AND CPS R202 GT R103 ; and "S" limitation from MDI > "S" limitation
from CNC
= CNCWR(R210,PLCSL,M1000) ; It does not limit "S" from PLC (R210=0)
;
DFD M100 ; At the end of execution
= CNCWR(R210,PLCSL,M1000) ; it cancels "S" limitation from the PLC
= CNCWR(R210,MDISL,M1000) ; and it resets the MDISL variable
;
END

```

## 20 Axes (2) controlled by a drive

Until this version, when having 2 axes controlled by a single drive, the polarity of the analog output (command sign) always corresponded to that of the main axis.

From this version on, since sometimes the turning direction of the two axes may be different, the sign of the command for each axis will taken into account [the one set by a.m.p "LOOPCHG (P26)"].

### Warning



*This new version is not compatible with previous versions.  
On machines having axes controlled by a single drive the secondary axis might run away.  
Before installing the new software, make sure that the a.m.p. "LOOPCHG (P26)" of the associated axis has the same value as that of the main axis.*

## 21 Mandatory home search

The CNC forces a home search on an axis by setting the relevant REFPOIN\* mark low in the following cases:

- On CNC power-up
- After executing SHIFT RESET
- When the feedback is direct through the axes board and a feedback alarm occurs.



NEW FEATURES

(SOFT M: 7.xx)

**Axes (2) controlled  
by a drive**

- When losing feedback count via Sercos due to broken communication. Difference greater than 10 microns (0.00039") or 0.01°
- When changing machine parameters that affect the memory distribution, for example: number of axes.

In all these cases, a home search must be carried out so the signal is set back high.

## 22 Change of active tool from the PLC

If the tool change process is interrupted, the values of the tool magazine table and active tool may not reflect the machine's reality.

To update the tool table, variables TOOL, NXTOOL, TOD and NXTOD that until now were read-only are now read-write from the PLC as long as a block or a part-program is not being executed or simulated.

TOOL	Number of the active tool
NXTOOL	Number of the next tool that is selected, but waiting for the execution of an M06 to become active.
TOD	Number of the active tool offset
NXTOD	Number of the offset of the next tool that is selected, but waiting for the execution of an M06 to become active.

This way, it is possible to resume the tool change from the PLC and redefine the tool table according to their positions using the TMZT variable.

To allocate a magazine position to the tool that is considered active by the CNC and is physically in the tool magazine, proceed as follows:

1. Cancel the tool, TOOL=0 and TOD=0
2. Assign the relevant position using the TMZT variable.

When trying to write in variables TOOL, NXTOOL, TOD and NXTOD check the OPMODA variable to make sure that no block or part-program is being executed or simulated. The following bits must be at "0".

OPMODA	
bit 0	Program in execution
bit 1	Program in simulation
bit 2	Block in execution via MDI, JOG
bit 8	Block in execution via CNCEX1

## 23 Synchronize a PLC axis with a CNC axis

To synchronize an axis of the PLC channel with another one of the CNC channel (main channel), set a.m.p. SYNCHRO (P3) of the PLC axis indicating which axis it must synchronize with.

Axis synchronization is carried out from the PLC by activating the general input "SYNCHRO" of the axis to be coupled as slave (PLC axis).

To assure that both axes are stopped when they are being synchronized, we suggest:



NEW FEATURES

(SOFT M: 7.xx)

Change of active tool from the PLC

- To execute a special M function at the CNC so the PLC executes another M function in the PLC channel and activates the general input "SYNCHRO".
- The M function of the main channel must not end until the PLC's M function execution is completed and the ENABLE signal of the slave axis is set high.

Once both axes are synchronized, it won't be possible to program movements of the PLC axis. Otherwise, error 1099 will be issued: "Do not program a slaved axis".

During synchronization, it does not check whether the PLC axis gets in position or not. For this reason:

- The logic output "ENABLE" of the PLC axis is activated (allowing motion).
- The logic output "INPOS" of the PLC axis is deactivated (the axis is NOT in position).
- General input "INHIBIT" of the PLC axis is ignored, thus not being possible to prevent it from moving.
- The execution of the movement of the synchronized slave axis cannot be aborted even by activating the general input "PLCABORT".

If an error occurs canceling the "ENABLE" logic outputs of all the axes, it also cancels the synchronization.

To end synchronization, cancel the "SYNCHRO" general input of the PLC axis.

To assure that the PLC axis recovers its position after the synchronization, it is recommended to use other 2 special M functions, one at the CNC and another one at the PLC.

## 24 Error register

The "CNC" screen of the "STATUS" mode offers the softkey: [BB].

Pressing this softkey displays the error history indicating the error number and when it occurred.

This information is very useful to the service technician. Pressing the [SAVE] softkey requests the number of the CNC program to store that information.

If the service department asks you for that program, transfer it to a PC via DNC and send it to the corresponding address via internet.

## 25 Path JOG mode

It is similar to the "Path Handwheel" mode.

The "Path Handwheel" mode acts at the Handwheel position of the selector switch whereas the "Path JOG" acts at the continuous and incremental jog positions of the selector switch.

"Path JOG" may be used to act upon the jog keys of an axis to move both axes of the plane at the same time for chamfering (straight sections) and rounding (curved sections).

The CNC assumes as "Path JOG" the keys associated with the X axis.



NEW FEATURES

(SOFT M: 7.XX)

Error register

This feature must be managed from the PLC.

To turn on or off the "Path JOG" work mode, use CNC logic input "MASTRHND" M5054,

M5054 = 0 "Path JOG" function off.

M5054 = 1 "Path JOG" function on.

To indicate the type of movement, use CNC logic input "HNLINARC" M5053

M5053 = 0 Linear Path

M5053 = 1 Circular path.

For a linear path, indicate the path angle in the MASLAN variable (value in degrees between the linear path and the first axis of the plane)

For an arc, indicate the arc center coordinates in the MASCFI, MASCSE variables (for the first and second axes of the main plane)

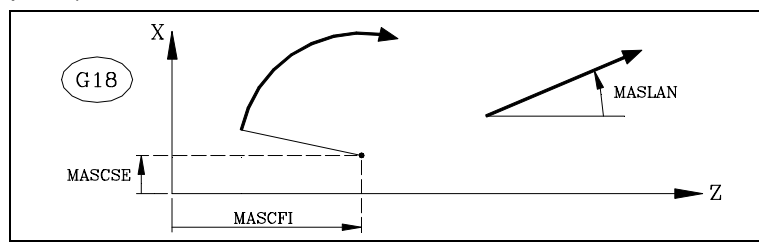

Variables MASLAN, MASCFI and MASCSE may be read and written from the CNC, DNC and PLC.

### Operation

When pressing one of the associated keys, X+ and X-, the CNC acts as follows:

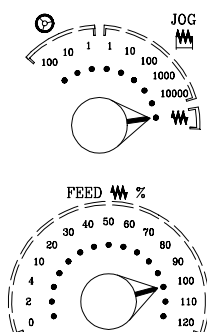

Selector Switch Position	Path JOG	Type of movement
Continuous	OFF	Only the axis and in the indicated direction
	ON	Both axes in the indicated direction along the indicated path
Incremental	OFF	Only the axis, the selected distance and in the indicated direction
	ON	Both axes, the indicated distance and direction, but along the indicated path
Handwheel		It ignores the keys.

The rest of the keys always operate the same way regardless of whether the "Path JOG" function is on or off. It only moves the selected axis and in the indicated direction.

### Considerations

It assumes as axis feedrate the one selected in JOG mode and it is affected by the override. If F0 is selected, it assumes the one indicated by a.m.p. "JOGFEED (P43)". The [Rapid] key is ignored.

The movements in "Path JOG" observe the travel limits and zone boundaries

The movements in "Path JOG" may be aborted:

- By pressing the [CYCLE STOP] key
- By selecting one of the handwheel positions of the JOG selector switch.



NEW FEATURES

(SOFT M: 7.XX)

Path JOG mode

- By setting the general logic input "MASTRHND (M5054)" =0.
- Setting the general logic input "\STOP (M5001)"=0.

## 26 Tool inspection

The tool inspection mode now offers a new option: "Modify Offsets". This window shows (at the top) a help graphic and the tool fields that can be edited.

When editing the active tool, it is possible:

To modify the I and K data.

Select another tool for calibration (T xx Enter).

When NOT editing the active tool, it is possible:

To modify the I, K and D data.

Select another tool for calibration (T xx Enter).

### The I and K values

The values entered in the I, K fields are incremental, they are added to the ones already in the table. The "I" data is given in diameter.

The new g.m.p. "MAXOFFI (P165)" and "MAXOFFK (P166)" indicate the maximum value that may be entered in each field. When trying to enter a greater value, the relevant message will be displayed.

### Warning



*To assume the new I and K values, select the tool again.*

## 27 New instructions in the configuration language

The new token "UNMODIFIED" of the configuration language indicates that the associated element must not take the editing focus.

### ;(UNMODIFIED)

It is programmed as a prefix of the instructions

;(W1=GUP100)

It may be used to associate the "W1" data with the value of a global parameter, variable or resource of the PLC and the "W1" element is assigned the editing focus.

;(AUTOREFRESH W6=FLWEX)

It refreshes (updates) the value of the graphic element W6 and it assigns the editing focus to it.

The resulting new instructions are:

;(UNMODIFIED W1=GUP170)

It associates the "W" data with the value of a global parameter, variable or resource of the PLC, but the "W1" element does not take the editing focus.

;(UNMODIFIED AUTOREFRESH W6=FLWEX)

It refreshes (updates) the value of the graphic element W6 but it does not take the editing focus.



NEW FEATURES

(SOFT M: 7.xx)

Tool inspection

## 28 Improvements in tool compensation

**COMPTYPE (P74)** From this version on, this g.m.p. has two digits.

The units set the beginning and end of radius compensation applied by the CNC (like it was before).

- x0 It approaches the starting point going around the corner
- x1 it goes directly perpendicular to the point (without going around the corner)

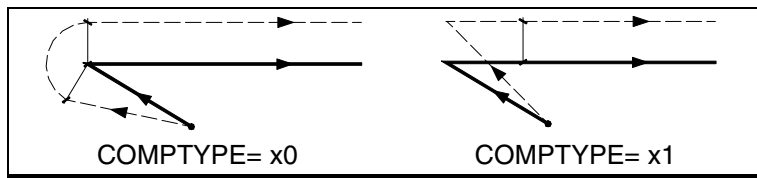

The tens indicate whether the additional block of the compensation is executed at the end of the current block or at the beginning of the next block with compensation.

00	<p>It is executed at the end of the current block (like in previous versions).</p> <p>Executing block by block (single block mode), the first movement ends at point "B".</p>
10	<p>It is executed at the beginning of the next block with compensation</p> <p>Executing block by block (single block mode), the first movement ends at point "A".</p>

By default COMPTYPE=00

When the beginning or end of the compensation takes place to a different plane (there is an intermediate vertical movement) and at an angle greater than 270° it is recommended to check the CNC's behavior as shown next:

At the beginning of the compensation, the tool should be positioned before penetrating into the part. The additional block must be



NEW FEATURES

(SOFT M: 7.xx)

Improvements in tool compensation

executed in the upper plane and therefore together with the first block "COMPTYPE=00".

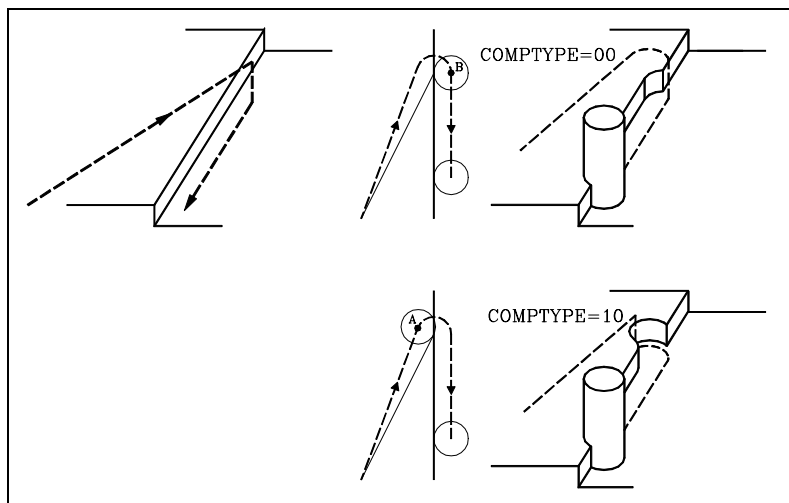

At the end of the compensation, the tool should withdraw from the part without penetrating into it. The additional block must be executed in the upper plane and therefore together with the second block "COMPTYPE=10".

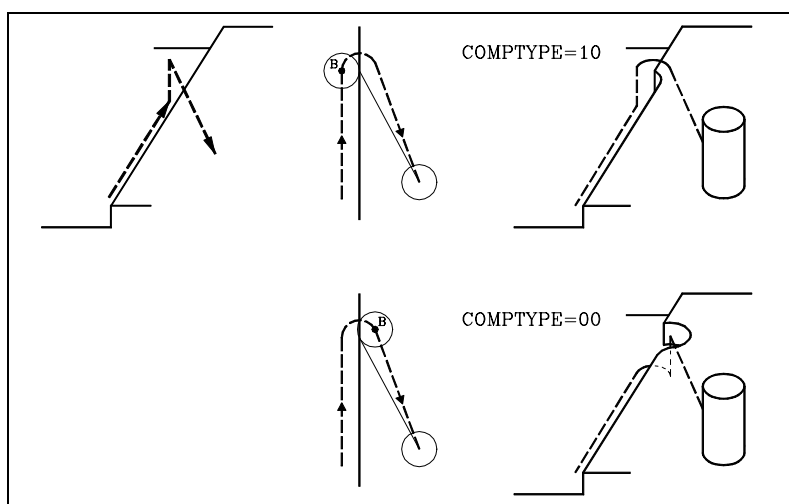

## 29 Improvements in high speed machining

The number of blocks analyzed in advance (look-ahead) has been increased. From 50 blocks to 75.

The extreme cases have been improved, such as small blocks (of a few microns) in order to machine faster and more smoothly.

Jerk control can now be applied in Look-ahead, g.m.p. "JERKACT (P160) and TLOOK (P161)".

Using Jerk in Look-ahead, a trapezoidal acceleration profile is applied with a ramp slope equivalent to the maximum jerk of the axis.

The maximum jerk depends on the value assigned to a.m.p. "JERKLIM (P67)" of that axis and of the axes involved in the programmed path.

**JERKACT (P160)** This parameter has 16 bits counted from left to right.

Bit 16 indicates whether to apply Jerk control in Look-ahead or not.

(0) Not applied.



NEW FEATURES

(SOFT M: 7.xx)

Improvements in  
high speed  
machining

(1) Applied.

By default 0 (not applied)

If "Jerk Control in look ahead" has been selected, the CNC analyzes the a.m.p "JERKLIM (P67)" of each axis. During look-ahead, the CNC assumes, for the axes with "JERKLIM (P67)=0", the value suggested in that parameter.

**TLOOK (P161)** Real block processing time for look-ahead.

If assigned a value smaller than the real one, the machine will vibrate and if assigned a value greater than the real one the machining slows down.

Possible values                      Integers between 0 and 65535 ms

By default 0

This value is calculated as follows:

Execute, in G91 and G51 E0.1, a program with many small blocks, at least 1000. For example: "X0.01 Y0.01 Z0.01".

Measure the program execution time, making sure that the machine does not vibrate. Divide the execution time by 1000 (or the number of blocks executed) and assign the resulting value, in microseconds, to g.m.p. "TLOOK (P161)".

We recommend the use of the oscilloscope function and verify that the internal variable VLOOKR remains constant which means that there is no vibration.

## 30 New graphics option

**GRAPHICS (P16)** New value (4) for g.m.p. GRAPHICS.

It is similar to "0" value (Mill model graphics) but with different XY line graphics.

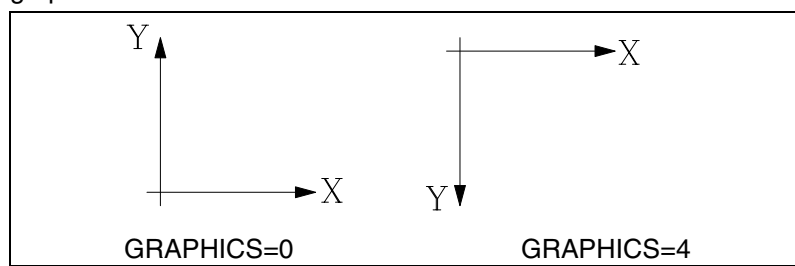

It is available when having Power PC.



NEW FEATURES

(SOFT M: 7.XX)

New graphics option

## 31 Improvement in the tool measuring cycle PROBE1

In previous version, this cycle only calibrated the length of the tool (see section 12.3 of the programming manual).

From this version on, it may be used:

- To calibrate the tool length.
- To calibrate the tool radius.
- To calibrate the tool radius and length.
- Measure the tool length wear.
- Measure the tool radius wear.
- Measure the tool radius wear and length wear.



The programming cycle for the PROBE1 cycle is:

(PROBE 1, B, I, F, J, K, L, C, D, E, S, M, C, N, X, U, Y, V, Z, W)

### Parameters X, U, Y, V, Z, W

They are optional parameters that are not usually necessary.

On certain machines, due to lack of mechanical positioning repeatability of the probe's, the probe must be calibrated before each tool calibration.

Instead of redefining machine parameters PRBXMIN, PRBXMAX, PRBYMIN, PRBYMAX, PRBZMAX, PRBZMIN every time the probe is calibrated, those coordinates may be indicated in variables X, U, Y, V, Z, W, respectively.

The CNC does not modify the machine parameters and only takes into account the coordinates indicated in X, U, Y, V, Z, W during this calibration.

If any of the X, U, Y, V, Z is left out, the CNC takes the value assigned to the corresponding machine parameter.

### 31.1 Measure or calibrate the tool length.

Parameter "I" defines where the measurement or calibration will be carried out:

I0 On the tool shaft.

I1 On the tool tip.

If not programmed, the canned cycle takes the value I0 (on the tool shaft).

#### Measure or calibrate the tool length on its shaft.

It is carried out with the spindle stopped. It is useful for drilling tools, ball end-mills, or tools whose diameter is smaller than the probe's probing surface.

Calibration format:

(PROBE 1, B, I0, F, J0, X, U, Y, V, Z, W)

Format for wear measurement:

(PROBE 1, B, I0, F, J1, L, C, X, U, Y, V, Z, W)

B	Safety distance, with positive value greater than "0".
I0	Measure or calibrate the tool length on its shaft.
F	Probing feedrate, in mm/min. or in inches/min.
J	J0 = Calibration; J1 = Measurement
L	Maximum length wear permitted (with J1 and when using tool life monitoring).
C	Behavior when exceeding the maximum wear allowed (L other than 0). C0 = Interrupts the execution for the user to select another tool. C1 = The cycle replaces the tool with another one of the same family.
X...W	Optional

Parameters J, L, C are optional. If not programmed, the following values are assumed:



NEW FEATURES

(SOFT M: 7.xx)

Improvement in the tool measuring cycle PROBE1

J0 (calibration). L0 (the tool is not rejected due to wear). C0 (interrupts the execution for the user to select another tool)

**Measure or calibrate the tool length on its tip.**

It may be carried out either with the spindle stopped or turning the in the programmed direction (opposite to the cutting direction) It is useful for calibrating tools with several cutting edges or tools whose diameter is greater than the probe's probing surface.

Calibration format:

(PROBE 1, B, I1, F, J0, D, S, N, X, U, Y, V, Z, W)

Format for wear measurement:

(PROBE 1, B, I1, F, J1, L, D, S, C, N, X, U, Y, V, Z, W)

B	Safety distance, with positive value greater than "0".
I1	Measure or calibrate the tool length on its tip.
F	Probing feedrate, in mm/min. or in inches/min.
J	J0 = Calibration; J1 = Measurement
L	Maximum length wear permitted (with J1 and when using tool life monitoring).
D	Radius or distance referred to the tool shaft being probed. If not programmed, it is done on the tip
S	Tool turning speed and direction. Select the opposite of the cutting direction (positive sign if M3 and negative if M4) With S0, calibration with spindle stopped.
C	Behavior when exceeding the maximum wear allowed (L other than 0) C0 = Interrupts the execution for the user to select another tool. C1 = The cycle replaces the tool with another one of the same family.
N	Number of cutting edges to be measured. If N0, one measurement. To measure each cutting edge when the spindle has feedback and s.m.p. M19TYPE (P43) =1.
X...W	Optional

Parameters J, L, D, S, C, N are optional. If not programmed, the following values are assumed:

J0 (calibration). L0 (the tool is not rejected due to wear). D= tool radius (probing is carried out on the tip). S0 (spindle stopped). C0 (interrupts the execution for the user to select another tool). N0 (the cutting edges are not measured separately).

**Once the calibration cycle has ended**

It updates global arithmetic parameter P299 and assigns the measured length to the tool offset selected in the tool offset table.

P299 = measured length - previous length (L+K)  
L = measured length  
K = 0

If the dimension of each cutting edge was requested, "N" parameter, the measured values are assigned to global arithmetic parameters P271 and on.

**Once the wear measuring cycle has ended**

When using tool life monitoring, it compares the measured value with the theoretical length assigned in the table.



NEW FEATURES

(SOFT M: 7.XX)

Improvement in the tool measuring cycle PROBE1

If the maximum allowed is exceeded, it issues a "tool rejected" message and acts as follows:

C0	It interrupts the execution for the user to select another tool.
C1	The cycle replaces the tool with another one of the same family. It sets the "rejected tool " indicator (status = R) It activates the general logic output PRTREJEC (M5564)

If the measuring difference does not exceed the maximum allowed or tool life monitoring is not available:

- It updates global arithmetic parameter P299 and the length wear value of the tool offset selected in the tool offset table.

P299 = measured length - theoretical length (L)

L = theoretical length (it maintains the previous value).

K = measured length - theoretical length (L) [New wear value]

If the dimension of each cutting edge was requested, "N" parameter, the measured values are assigned to global arithmetic parameters P271 and on.

### 31.2 Measure or calibrate the radius of a tool.

It may be carried out either with the spindle stopped or turning the in the programmed direction (opposite to the cutting direction)

Calibration format:

(PROBE 1, B, I2, F, J0, K, E, S, N, X, U, Y, V, Z, W)

Format for wear measurement:

(PROBE 1, B, I2, F, J1, K, E, S, M, C, N, X, U, Y, V, Z, W)

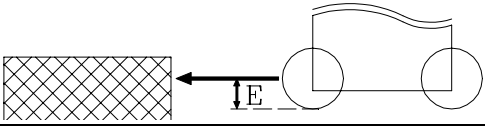
B	Safety distance, with positive value greater than "0".
I2	Measure or calibrate the radius of a tool.
F	Probing feedrate, in mm/min. or in inches/min.
J	J0 = Calibration; J1 = Measurement
K	Probe side used. K0 (X+ side), K1 (X- side), K2 (Y+ side), K3 (Y- side).
E	Distance referred to the theoretical tool tip being probed. It is very useful with cutters whose bottom is not horizontal. 
S	Tool turning speed and direction. Select the opposite of the cutting direction (positive sign if M3 and negative if M4) With S0, calibration with spindle stopped.
M	Maximum radius wear permitted (with J1 and when using tool life monitoring).
C	Behavior when exceeding the maximum wear allowed (M other than 0). C0 = Interrupts the execution for the user to select another tool. C1 = The cycle replaces the tool with another one of the same family.
N	Number of cutting edges to be measured. If N0, one measurement. To measure each cutting edge when the spindle has feedback and s.m.p. M19TYPE (P43) =1.
X...W	Optional

Parameters J, E, S, M, C, N are optional. If not programmed, the following values are assumed:



NEW FEATURES

(SOFT M: 7.xx)

Improvement in the  
tool measuring  
cycle PROBE1

J0 (calibration). E0. S0 (spindle stopped). M0 (the tool is not rejected due to wear). C0 (interrupts the execution for the user to select another tool). N0 (the cutting edges are not measured separately).

### Once the calibration cycle has ended

It updates global arithmetic parameter P298 and assigns the measured radius to the tool offset selected in the tool offset table.

P298 = measured radius - previous radius (R+I)  
 R = measured radius  
 I = 0

If the dimension of each cutting edge was requested, "N" parameter, the measured values are assigned to global arithmetic parameters P251 and on.

### Once the wear measuring cycle has ended

When using tool life monitoring, it compares the measured value with the theoretical radius assigned in the table.

If the maximum allowed is exceeded, it issues a "tool rejected" message and acts as follows:

C0	It interrupts the execution for the user to select another tool.
C1	The cycle replaces the tool with another one of the same family. It sets the "rejected tool " indicator (status = R) It activates the general logic output PRTREJEC (M5564)

If the measuring difference does not exceed the maximum allowed or tool life monitoring is not available:

- It updates global arithmetic parameter P298 and the radius wear value of the tool offset selected in the tool offset table.

P298 = measured radius - theoretical radius (R)  
 R = theoretical radius (it maintains the previous value).  
 I = measured radius - theoretical radius (R) [New wear value]

If the dimension of each cutting edge was requested, "N" parameter, the measured values are assigned to global arithmetic parameters P271 and on.

## 31.3 Measure or calibrate the tool radius and length.

It may be carried out either with the spindle stopped or turning the in the programmed direction (opposite to the cutting direction)

Calibration format:

(PROBE 1, B, I3, F, J0, K, D, E, S, N, X, U, Y, V, Z, W)

Format for wear measurement:

(PROBE 1, B, I3, F, J1, K, L, D, E, S, M, C, N, X, U, Y, V, Z, W)

B	Safety distance, with positive value greater than "0".
I3	Measure or calibrate the tool radius and length.
F	Probing feedrate, in mm/min. or in inches/min.
J	J0 = Calibration; J1 = Measurement
K	Side of the probe used to measure or calibration the radius. K0 (X+ side), K1 (X- side), K2 (Y+ side), K3 (Y- side).
L	Maximum length wear permitted (with J1 and when using tool life monitoring).



NEW FEATURES

(SOFT M: 7.xx)

Improvement in the tool measuring cycle PROBE1

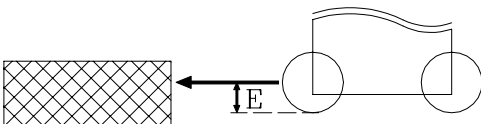
D	Radius or distance referred to the tool shaft being for length measurement or calibration. With D0 on the tool shaft and if not programmed, on the tip.
E	Distance referred to the theoretical tool tip being probed. It is very useful with cutters whose bottom is not horizontal. 
S	Tool turning speed and direction. Select the opposite of the cutting direction (positive sign if M3 and negative if M4) With S0, calibration with spindle stopped.
M	Maximum radius wear permitted (with J1 and when using tool life monitoring).
C	Behavior when exceeding the maximum wear allowed (if L or M other than 0). C0 = Interrupts the execution for the user to select another tool. C1 = The cycle replaces the tool with another one of the same family.
N	Number of cutting edges to be measured. If N0, one measurement. To measure each cutting edge when the spindle has feedback and s.m.p. M19TYPE (P43) =1.
X...W	Optional

Parameters J, L, D, E, S, M, C, N are optional. If not programmed, the following values are assumed:

J0 (calibration). L0 (the tool is not rejected due to length wear). D= tool radius (length probing is carried out on the tip). E0, S0 (spindle stopped). M0 (the tool is not rejected due to radius wear). C0 (interrupts the execution for the user to select another tool). N0 (the cutting edges are not measured separately).

### Once the calibration cycle has ended

It uses global arithmetic parameters P298, P299 and assigns the measured length and radius to the tool offset selected in the tool offset table.

- P298 = measured radius - previous radius (R+I)
- P299 = measured length - previous length (L+K)
- R = measured radius
- L = measured length
- I = 0
- K = 0

If the dimension of each cutting edge was requested, parameter "N", the measured lengths are assigned to global arithmetic parameters P271 and on, and the measured radii to global arithmetic parameters P251 and on.

### Once the wear measuring cycle has ended

When using tool life monitoring, it compares the measured radius and length values with the theoretical values assigned in the table.

If the maximum allowed is exceeded in any of them, it issues a "tool rejected" message and acts as follows:

C0	It interrupts the execution for the user to select another tool.
C1	The cycle replaces the tool with another one of the same family. It sets the "rejected tool" indicator (status = R) It activates the general logic output PRTREJEC (M5564)



NEW FEATURES

(SOFT M: 7.xx)

Improvement in the tool measuring cycle PROBE1

If the measuring difference does not exceed the maximum allowed or tool life monitoring is not available:

- It updates global arithmetic parameter P298, P299 and the length and radius wear values of the tool offset selected in the tool offset table.

P298 = measured radius - theoretical radius (R)

P299 = measured length - theoretical length (L)

R = theoretical radius (it maintains the previous value).

I = measured radius - theoretical radius (R) [New wear value]

L = theoretical length (it maintains the previous value).

K = measured length - theoretical length (L) [New wear value]

If the dimension of each cutting edge was requested, parameter "N", the lengths are assigned to global arithmetic parameters P271 and on, and the radii to global arithmetic parameters P251 and on.

## 32 Oscilloscope function

The oscilloscope function is a help tool to adjust the CNC and the drives.

It is possible to represent 4 previously selected variables and manipulate CNC machine parameters and variables. When using Fagor Sercos drives, it is also possible to set the parameters of the drive.

When requesting information (variable or parameter) of a drive that is not connected via Sercos or when having an old software version, the message "Variable does not exist" will be displayed.

Changing the machine parameters of the CNC and the drive requires a password.

### How to operate

To access the Oscilloscope mode, select:

Op Mode - Diagnosis - Adjustements - Scope

Define the variables to be analyzed, the trigger conditions and the machine parameters of the CNC or the drive to be modified.

Execute a part-program moving the axis or axes to be adjusted.

Capture data and then analyze it.

Once data capture has ended, or has been interrupted, it is possible to analyze the signals and modify the parameters that have been previously selected, in order to improve the machining conditions.

Capture data, analyze it and modify the parameters again until achieving the best machining conditions.

### Suggestions

Execute endless repetitive movements.

After adjusting the axis separately, readjust the interpolating axes together.

It is up to the user to judge what the best adjustment is, the oscilloscope function is an assistance tool.

### Operation

To enter or modify a data on the screens, it must be selected and it must have the editing focus.



NEW FEATURES

(SOFT M: 7.XX)

Oscilloscope  
function

To select another editable data or field, use the [↑] [↓]. It is a rotary selection, if the first element is selected on the screen, when pressing [↑] the focus goes to the last one, whereas if the last element is selected, when pressing [↓] the focus goes to the first one.

Not all the data may be edited, only the ones that may be selected, those having the focus. There are two types of editable fields:

Editable values:

They may be assigned a value, sometimes numerical (numbers only) and sometimes alphanumerical (numbers and letters). Before validating the data, it is checked; if the data is incorrect, it is rejected and a warning message is issued.

Values that may be selected:

The possible values are fixed and one of them may be selected. Use the [←] [→] keys to see the possible values. On this type values that are icons, the [White/Green] key has the same effect as the [→] key.

## Softkeys

Accessing the oscilloscope mode enables the following softkeys:

Scale / Offsets

To change the amplitude of each signal, move them vertically or adjust the time base for all of them.

Analysis

To analyze, using 2 cursors, each signal of the last data capture.

Parameters

To assign new values to the machine parameters of the CNC and drive that have been defined in the "Configuration" screen.

Configuration

To define the variables to be analyzed, the trigger conditions and the machine parameters of the CNC or the drive to be modified.

Actions

It shows various softkeys to modify the data of each field (amplitude of the signals, vertical movement, time base adjustment, position of the cursors, etc.).

Begin

It captures data according to the conditions set on the "Configuration" screen to be analyzed later on.

## 32.1 Configuration

To define the variables to be analyzed, the trigger conditions and the machine parameters of the CNC or the drive to be modified.

It offers 2 screens, one to set the parameters and the other one to define the variables and trigger conditions.

On the screen for defining variables and the trigger condition, it is possible to go from block of elements to another using the [page up] and [page down] keys.



NEW FEATURES

(SOFT M: 7.XX)

Oscilloscope  
function

The parameters defining page shows the definition code on the left column, the parameter name on the center column and the maximum and minimum values on the right column.

To add a parameter to the list, select the row for the parameter, enter the definition code indicated later on and press [Enter]. If it is valid, the rest of the fields are updated and if not, it issues a warning.

To replace a parameter from the list, select the parameter to be replaced, enter the definition code of the new parameter and press [Enter]. If the previous content has been deleted and no code is entered, the line appears empty.

The [Add a parameter to the list] softkey enters a new empty line above the currently selected line.

The [Eliminate parameter] softkey eliminates the currently selected line and shifts all the ones below upwards.

The "Parameter editing" screen shows the parameters in the same place where they were defined and the empty rows appear blank.

When a parameter is changed on the "Parameter Editing" screen, the CNC machine parameter table and the drive's work parameters are updated. The [Save Parameters] softkey is also activated on the "Configuration - Parameters" screen.

We suggest to access that screen and press the [Save Parameters] softkey to save the parameter tables that have been changed, those of the CNC into the CARDA and those of the drive in its FLASH. If only the CNC parameters have been changed, the drive tables remain unchanged and vice versa.

Once the values saved are the same as the ones edited last, the softkey disappears until a new modification is made.

## Variable definition

The oscilloscope has 4 graphics channels (CH1, CH2, CH3, CH4). The following must be defined in each channel:

- The code or name of the variable to be shown. See attached tables.
- The color used to show them.
- Whether it will be visible or not.

When defining a variable that cannot be captured, an error message will be issued. If no variable is to be captured in a channel, just leave the name field blank. If all 4 channels are deactivated (without associated variable) no capture is possible.

The "hidden" channels are not shown graphically (they are not shown on the screen after the data capture). It is useful when using this channel to set the trigger condition.



NEW FEATURES

(SOFT M: 7.XX)

Oscilloscope  
function



## CNC variables that may be assigned to a channel

Variable	Characteristics
ANAI(1-8)	Voltage of input 1-8
ANAO(1-8)	Voltage to apply to output 1-8
FREAL	CNC real feedrate
FREAL(X-C)	Actual (real) X-C axis feedrate
FTEO(X-C)	Theoretical X-C axis feedrate
FLWE(X-C)	X-C axis following error
ASIN(X-C)	"A" signal of the CNC sinusoidal feedback for the X-C axis
BSIN(X-C)	"B" signal of the CNC sinusoidal feedback for the X-C axis
DRPO(X-C)	Position indicated by the Sercos drive of the X-C axis
SREAL	Real (actual) spindle turning speed.
FTEOS	Theoretical spindle turning speed
FLWES	Spindle following error
ASINS	"A" signal of the CNC sinusoidal feedback for the spindle
BSINS	"B" signal of the CNC sinusoidal feedback for the spindle
DRPOS	Position indicated by the Sercos drive of the spindle
SSREAL	Real (actual) second spindle turning speed.
SFTEOS	Theoretical second spindle turning speed
SFLWES	Second Spindle following error
SASINS	"A" signal of the CNC sinusoidal feedback for the second spindle
SBSINS	"B" signal of the CNC sinusoidal feedback for the second spindle
SDRPOS	Position indicated by the Sercos drive of the second spindle

Examples: ANAI1, FREAL, FLWEX, FREALZ

## Fagor Sercos Drive variables that may be assigned to a channel

Indicate the desired axis and variable, separated by a period.

Examples: X.CV3, Y.SV1, S1.SV2

Variable	Characteristics
CV3	CurrentFeedback
SV1	VelocityCommand
SV2	VelocityFeedback
SV7	VelocityCommandFinal
TV1	TorqueCommand
TV4	VelocityIntegralAction
RV1	FeedbackSine
RV2	FeedbackCosine
RV51	Feedback2Sine
RV52	Feedback2Cosine

### Trigger conditions

- Channel** Indicates which variable or channel (CH1, CH2, CH3, CH4) is to be used as a reference or trigger condition.
- Trigger** Indicates the beginning of the data capture.
- If not selected, the data capture begins as soon as the operator gives the go ahead. The Flank, Level and Position data are ignored.
- If selected, specify the trigger condition using the Flank, Level and Position data.
- Flank** It is taken into account when Trigger has been selected. It may be an up flank or a down flank.



NEW FEATURES

(SOFT M: 7.xx)

Oscilloscope  
function

With an up flank, the data capture begins when in a sample the data value is lower than the level and in the next sample the value is greater than or equal to the level.

With a down flank, the data capture begins when in a sample the data value is greater than the level and in the next sample the value is lower than or equal to the level.

**Level** It is taken into account when Trigger has been selected.

It sets the value that the variable must take to begin the data capture.

**Position (%)** It is taken into account when Trigger has been selected. It is defined as a percentage, between 0% and 100%.

It indicates the number of samples that are taken before the Trigger. For example, a 10% position means that 10% of the total number of samples programmed will be taken before the trigger and the remaining 90% after the trigger.

The trigger condition starts evaluating after having the indicated % of samples. If the position is defined at 50% and the trigger condition occurs when a 10% of the samples have been taken, it will be ignored until the 50% of the samples have been collected.

**Number of samples** It indicates the number of sample to be captured. It is common to all the channels. Value between 1 and 1024.

The sample will be taken at the same time in all the channels so they are synchronized.

**Sample T** It indicates the sample period or the time period between data captures. It is given in milliseconds, integers between 1 and 1000 (between 1ms and 1s).

When analyzing CNC variables, the sample period must be a multiple of the loop time. If it is not, a message is displayed indicating that it has been automatically rounded off.

The sample time may be shorter than the CNC loop time only when analyzing 1 or 2 variables of the same drive.

When the requested number of variables forces a reconfiguration of the CNC's Sercos ring, a warning message is issued requesting its confirmation.

**Mode** It indicates the type of data capture: Single or Continuous.

With Single capture, the process ends when the specified number of samples has been taken or when interrupted by the user.

The continuous data capture begins like a single capture, but when the process ends, the data is shown on the screen and it automatically resumes the data capture. It goes on like that indefinitely until the user stops it.

**Superimposed channels** If this option is not selected, all the signals appear separated. The screen is divided into as many horizontal strips as active and visible channels have been defined. The signals are shown with their own graphic zero and ordered from top to bottom in the defined order (CH1, CH2, CH3, CH4).

If this option is selected all the signals appear superimposed, with a single graphic zero located at the center of the screen.

During the analysis of the signals, it is possible to change modes by pressing the [M] key.



NEW FEATURES

(SOFT M: 7.XX)

Oscilloscope  
function

## CNC machine parameters that may be modified

When defining the CNC machine parameters, that could be changed to adjust the machine, use the following nomenclature:

Machine parameters of an axis: Indicate the axis and the parameter number separated by a dot. Examples: [X.P18], [Z.P23]

Number	Parameter	Update
P14	BACKLASH	Immediate
P18	ACCTIME	Beginning of the next block
P19	INPOSW	Immediate
P23	PROGAIN	Immediate
P24	DERGAIN	Immediate
P25	FFGAIN	Immediate
P27	MINANOUT	Immediate
P28	SERVOFF	Immediate
P29	BAKANOUT	Immediate
P30	BAKTIME	Immediate
P37	MAXVOLT	Immediate
P38	G00FEED	Beginning of the next block
P59	ACCTIME2	Beginning of the next block
P60	PROGAIN2	Immediate
P61	DERGAIN2	Immediate
P62	FFGAIN2	Immediate
P67	JERKLIM	Beginning of the next block

Spindle machine parameters: Indicate the spindle (S, S1, S2) and the parameter number separated by a dot. Examples: [S.P18], [S1.P23], [S2.P25]

Number	Parameter	Update
P2	MAXGEAR1	Beginning of the next block
P3	MAXGEAR2	Beginning of the next block
P4	MAXGEAR3	Beginning of the next block
P5	MAXGEAR4	Beginning of the next block
P18	ACCTIME	Beginning of the next block
P19	INPOSW	Immediate
P23	PROGAIN	Immediate
P24	DERGAIN	Immediate
P25	FFGAIN	Immediate
P27	MINANOUT	Immediate
P28	SERVOFF	Immediate
P37	MAXVOLT1	Immediate
P38	MAXVOLT2	Immediate
P39	MAXVOLT3	Immediate
P40	MAXVOLT4	Immediate
P45	OPLACET1	Immediate
P47	ACCTIME2	Beginning of the next block
P48	PROGAIN2	Immediate
P49	DERGAIN2	Immediate
P50	FFGAIN2	Immediate

**Note:** A modification in the MAXGEAR1/2/3/4 parameters sets the square corner mode even if a round corner has been programmed.

## Drive machine parameters that may be modified

When defining the drive machine parameters, that could be changed to adjust the machine, use the following nomenclature:



NEW FEATURES

(SOFT M: 7.xx)

Oscilloscope  
function

Indicate the axis and the parameter number and the gear separated by a dot. Examples: [X.CP1.0], [Y.CP20.2], [Z.SP1.1]

### Save and load the configurations.

The system lets you save the current configuration into a program type file in ASCII format. To do that, set general machine parameter STPFILE with the number (other than 0) to be assigned to the configuration file.

The configuration file may be treated like any other program, sent out via DNC or even edited.

When saving or loading a configuration, the CNC first checks if the file already exists in User RAM and if not, it will look for it in the Memkey Card.

Several configurations may be saved in the configuration file. Each configuration must be assigned a name of up to 40 characters.

The following softkeys are related to this feature.

- Save** To save the current configuration, press the [Save] softkey and enter the name to save it with up to 40 characters. If there is a previously saved configuration with the same name, it will ask whether it must be replaced or not.
- Load** To load a previously saved configuration, press the [Load] softkey and select it from the list on the screen. If the configuration makes not sense (for example, because the CNC does not have an axis that that configuration refers to), the CNC will warn the user and it will only load the portion of the configuration read until that error came up.
- Delete** To delete one of the saved configurations, press the [Delete] softkey, select it from the list on the screen and press [Enter].
- Reset** Pressing the [Reset] softkey deletes or resets the current configuration. There are no variables or parameters selected and the rest of conditions (colors, trigger, etc.) assume the values assigned by default.

## 32.2 Scale / Offsets

To change the amplitude of each signal, move them vertically or adjust the time base for all of them.

The right side of the screen shows:

- The vertical scale or amplitude by square for each signal (next to the name of the variable)
- The horizontal scale or time base (t/div) for all the signals.

To change the amplitude, use the [↑] [↓] keys to place the focus in the "Scale" field of the desired variable. Then use the [←] [→] keys or [page up] [page down] to select one of the permitted values or press [X] for auto-scaling.

To move the signal vertically, use the [↑] [↓] keys to place the focus in the "Offset" field of the desired variable. Then use the [←] [→] keys or [page up] [page down] to move the signal or press one of these keys:

- [U] To move it up as high as possible
- [D] To move it down as low as possible



NEW FEATURES

(SOFT M: 7.XX)

Oscilloscope  
function

- [0] To center it
- [X] for the CNC to scale it automatically.

When auto-scaling a channel, the system sets the right vertical scale and offset so the signal shows as big as possible within its graphic strip.

To modify the time base of all the signals, use the [↑] [↓] keys to place the focus in the "t/div" field. Then use the [←] [→] keys or [page up] [page down] to select one of the permitted values or press [X] for auto-scaling.

To select another portion of the sample use the [↑] [↓] keys to place the focus in the "Win" field. Then use the [←] [→] keys or [page up] [page down] to move the signal or press one of these keys:

- [F] To show the beginning of the trace (First)
- [T] To show the trigger zone
- [S] To show the final portion of the trace (Second)
- [X] for the CNC to scale it automatically.

### 32.3 Analysis

To analyze, using 2 cursors, each signal of the last data capture.

The right side of the screen shows:

- Next to each variable, the value (V1 and V2) of the signal in the position of each cursor and the difference between them ( $\Delta v$ ).
- The position, in milliseconds, of each cursor (C1 and C2) and the time difference between them ( $\Delta t$ )

To select the first or second cursor, use the teclas [↑] [↓] keys to place the focus in the "C1" or "C2" fields respectively. Then use the [←] [→] keys or [page up] [page down] to move the signal or press one of these keys:

- [F] To show the beginning of the trace (First)
- [T] To show the trigger zone
- [S] To show the final portion of the trace (Second)
- [X] for the CNC to scale it automatically.

To select another portion of the sample use the [↑] [↓] keys to place the focus in the "Win" field. Then use the [←] [→] keys or [page up] [page down] to move the signal or press one of these keys:

- [F] To show the beginning of the trace (First)
- [T] To show the trigger zone
- [S] To show the final portion of the trace (Second)
- [X] for the CNC to scale it automatically.

Holding the [←] [→] keys pressed accelerates the movement.

### 32.4 Parameters

To assign new values to the machine parameters of the CNC and drive that have been defined in the "Configuration-Parameters" screen.



NEW FEATURES

(SOFT M: 7.XX)

Oscilloscope  
function

The machine parameters of the axis or the spindle are updated according to the criteria defined in the previous tables, the rest of the parameters are updated according to the general criteria:

- // It is necessary to press the keystroke sequence: "Shift - Reset" or turn the CNC off and back on.
- / Just press Reset.

The rest of the parameters (those unmarked) will be updated automatically, only by changing them.

If the password to the machine parameters has been defined (SETUPPSW), it will be requested when modifying a parameter for the first time. If entered correctly, it is stored in memory and it is not requested again unless the CNC is turned off. If the password is wrong, the parameter cannot be modified and it will be requested again the next time.

When a parameter is changed, the CNC machine parameter table and the drive's work parameters are updated. The [Save Parameters] softkey is also activated on the "Configuration - Parameters" screen.

We suggest to access that screen and press the [Save Parameters] softkey to save the parameter tables that have been changed, those of the CNC into the CARDA and those of the drive in its FLASH. If only the CNC parameters have been changed, the drive tables remain unchanged and vice versa.

Once the values saved are the same as the ones edited last, the softkey disappears until a new modification is made.

## 32.5 Actions

It is available on the following screens: "Parameter Editing", "Analysis" and "Scales /Offsets".

It is very useful when not having an alpha-numeric keyboard (MC or MCO operator panels) because it shows several softkeys to change the data of each field (amplitude of the signals, vertical movement, time base, position of the cursors, etc.)

## 32.6 Begin

It is available on the following screens: "Parameter Editing", "Analysis" and "Scales /Offsets".

It captures data according to the conditions set on the "Configuration" screen and enables the following softkeys:

[Stop]

interrupts the capture and shows the data collected until then.

[Continuous Stop]

available when the capture is continuous. It interrupts the capture and shows the last full trace.

Once data capture has ended, or has been interrupted, it is possible to analyze the signals and modify the parameters that have been previously selected, in order to improve the machining conditions.

Capture data, analyze it and modify the parameters again until achieving the best machining conditions.



NEW FEATURES

(SOFT M: 7.XX)

Oscilloscope  
function

### 33 MC model. Execute a part-program



(Start)

After accessing the list of stored part-programs and selecting the program to be executed from the left column, it is possible to:

1. Execute the whole part-program.

Position, on the left column, over the desired program and press (Start).

Subroutine 9998 is executed before the part-program and subroutine 9999 after the part-program.

2. Execute a portion of the part-program.

Select the program from the left column and the operation (on the right column) from which to begin executing the part program and press the (Start) key.

In this case, the initial 9998 subroutine is not executed, only the part-program and the 9999 subroutine are executed.

3. Execute the part-program starting at the first operation.

Select the program from the left column and the first operation from the right column and press the (Start) key.

Subroutine 9998 is executed before the part-program and subroutine 9999 after the part-program.

**Note:** Programs created in ISO mode do not have subroutines 9998 and 9999.

### 34 MC model. Maintain F, S y Smax on power up

**MAINTASF (P162)** This g.m.p indicates whether on CNC power-up, the F, S and Smax values are maintained or initialized.

- 0 They are initialize with the values of F=0, S=0 and Smax=0
- 1 F, S and Smax maintain the values they had in the last machining operation.

With "MAINTASF (P162)=1", the CNC acts as follows:

- It assumes the G94/G95 feedrate set by g.m.p. "IFEED (P14)", but it restores the F in mm/min (G94) and the F in mm/rev (G95) programmed last.
- It maintains the feedrate type G96/G97 used last, but it restores the S in rev/min (G97) and the S in m/min (G96) programmed last.

### 35 MC model. Messages and warnings

From this version on, some messages that come up in M mode at the bottom of the screen over a green stripe will also come up in MC mode. For example:

"Software limit reached"  
"Zone limit reached"

### 36 MC model. Tool calibration

When accessing the tool calibration mode, there are a some limitation during execution or tool inspection



NEW FEATURES

(SOFT M: 7.xx)

MC model. Execute a part-program

**Program in execution or interrupted.**

When editing the active tool, it is possible:

To modify the I and K data.

Select another tool (T xx Recall) and modify its I and K data.

When NOT editing the active tool, it is possible:

To modify the I, K and D data.

Select another tool (T xx Recall) and modify its I, K and D data.

**Program in tool inspection.**

When editing the active tool, it is possible:

To modify the I and K data.

Select another tool (T xx Recall) and modify its I and K data.

Change the active tool (T xx Start).

When NOT editing the active tool, it is possible:

To modify the I, K and D data.

Select another tool (T xx Recall) and modify its I, K and D data.

Change the active tool (T xx Start).

**Rest of cases (program neither in execution nor in tool inspection)**

When editing the active tool, it is possible:

Modify all the data.

Change the active tool (T xx Start).

When NOT editing the active tool, it is possible:

Modify all the data except the part dimensions.

Change the active tool (T xx Start).

**The I and K values**

The values entered in the I, K fields are incremental, they are added to the ones already in the table. The "I" data is given in diameter.

The new g.m.p. "MAXOFFI (P165)" and "MAXOFFK (P166)" indicate the maximum value that may be entered in each field. When trying to enter a greater value, the relevant message will be displayed.

**Warning**

*To assume the new I and K values, select the tool again.*



NEW FEATURES

(SOFT M: 7.XX)

MC model. Cycle selection

**37 MC model. Cycle selection**

From this version on, it is possible to hide unused operations or cycles and only show the used ones.



- COCYF1 (P148)** Each one of these g.m.p. is associated with an operation or cycle and each one of their bits refers to each available level.
- COCYF2 (P149)**
- COCYF3 (P150)** All the bits are initialized to "0", available option. To hide the desired one, set the corresponding bit to "1".
- COCYF4 (P151)**
- COCYF5 (P152)**
- COCYF6 (P153)**
- COCYF7 (P154)**
- COCYZ (P155)**
- COCYPOS (P156)**
- COCYPROF (P157)**
- COCYGROO (P158)**
- COCYZPOS (P159)**

Operations or Cycles				
<b>COCYF1</b>	Probe 1 (bit 2)			
<b>COCYF2</b>				
<b>COCYF3</b>	Profile milling 1 (bit 1)	Profile milling 2 (bit 2)		
<b>COCYF4</b>	Surface milling (bit 1)	Slot milling (bit 2)		
<b>COCYF5</b>	Pocket with 2D profile (bit 1)	Pocket with 3D profile (bit 2)		
<b>COCYF6</b>	Rectangular boss (bit 1)	Circular boss (bit 2)		
<b>COCYF7</b>	Rectangular pocket 1 (bit 1)	Rectangular pocket 2 (bit 2)	Circular pocket 1 (bit 3)	Circular pocket 2 (bit 4)
<b>COCYZ</b>	Drilling 1 (bit 1)	Drilling 2 (bit 2)	Drilling 3 (bit 3)	Center punching (bit 4)
	Tapping (bit 7)	Reaming (bit 10)	Boring 1 (bit 12)	Boring 2 (bit 13)
<b>COCYPOS</b>	Positioning 1 (bit 1)	Positioning 2 (bit 2)		
<b>COCYPROF</b>				
<b>COCYGROO</b>				
<b>COCYZPOS</b>				

Multiple positioning				
<b>COCYZPOS</b>	At several points (bit 1)	In line (bit 4)	In arc 1 (bit 7)	In polar arc (bit 8)
	In grid pattern (bit 10)	Parallelogram (bit 13)		

### 38 MC model. Auxiliary M functions in all the cycles

From this version on, the operations or cycles of the MC model may have auxiliary M functions associated with roughing and finishing operations.

There are now 2 windows, one in the roughing area and another one in the finishing area and the use may define up to 4 auxiliary M functions in each one.

The auxiliary functions are executed at the beginning of the stage where they have been defined, roughing or finishing.

To use this feature, set g.m.p. "CODISET (P147)" (Conversational Display SETing).



NEW FEATURES

(SOFT M: 7.xx)

**MC model.  
Auxiliary M  
functions in all the  
cycles**

**CODISET (P147)** This parameter has 16 bits counted from left to right.

Bit 16 indicates whether the operations or cycles of the MC model have auxiliary M functions associated with roughing and finishing operations.

(0) They do not have auxiliary M functions

(1) They do not have auxiliary M functions

By default 0 (they do not have them)

### 39 MC model. Modifications in the tapping cycle

From this version on, it is possible to specify the thread by defining the pitch (p) the spindle speed (S) or the feedrate (F) and the spindle speed (S).



To do that, the "Penetration" area shows an icon with 2 states [p, S] and [F, S]. To select the desired one, place the cursor over the icon and press the (a) key, this will enable the fields selected to define it.

### 40 MC model. Modifications in the Multiple milling and positioning cycles

All the modifications or improvements have to do with the definition of intermediate points of the profile milling cycle (level 1) and the cycle for multiple positioning of several points.

#### Repeat previous coordinate

If a coordinate is left blank, the cycle will assume that it is a repetition of the previous one. Example:

```
X1 25.323 Y1 26.557
X2          Y2 78.998 Point X2 25.323 Y2 78.998
X3 67.441 Y3 83.231 Point X3 67.441 Y3 83.231
X4          Y4
X5          Y5
```

There are no more points, it is a repetition of the previous point

#### Incremental coordinates

The coordinates of each point may also be defined incrementally. To do that, position over the desired coordinate and press the (a) key.



The X and Z coordinates of the selected point will be shown preceded by the "Δ" icon that indicates the incremental value with respect to the previous point.

### 41 MC model. Icon indicating the available options

The multiple positioning in line, arc (level 1), in grid pattern and in rectangular pattern may be defined in different ways.

In this cases, an icon is added showing the selected option and the number of total options available. For example [1 of 3].



To select another option, place the cursor over the icon and press the (a) key.

## 42 MC model. Tool measurement and calibration

Available with the "Canned cycles with Probe" option and if the parameters that define the tabletop probe position g.m.p. PRBXMIN (P40), PRBXMAX (P41), PRBYMIN (P42), PRBYMAX (P43), PRBZMIN (P44) and PRBZMAX (P45) have been defined.

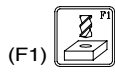

(F1)

To access this mode, press the [F1] key. The first level corresponds to "Tool calibration" and the second level to "Tool measurement and calibration with a probe".

The screen for "Tool measurement and calibration with a probe" may be saved as part of a part-program (PPROG) and shows the following information:

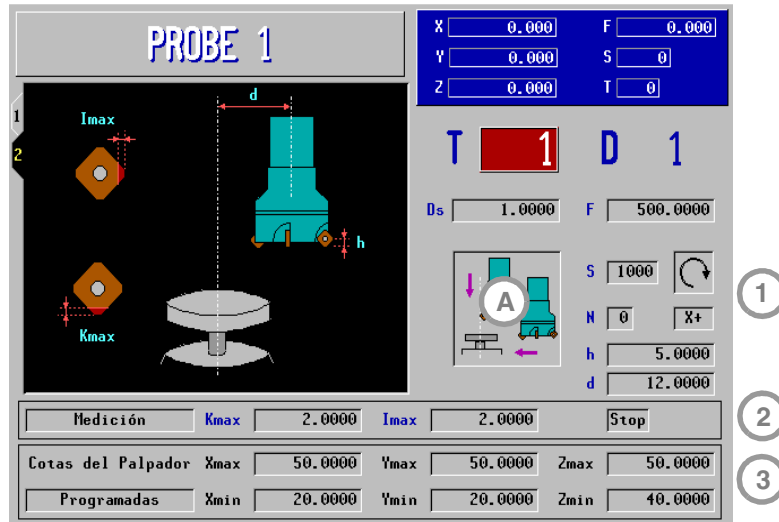

In zone (1) the following may be defined:



(a)

Ds	Safety distance, for the probe approach.
F	Probing feedrate.
(A)	Type of calibration or measurement. <ul style="list-style-type: none"> <li>• Calibrate the length or measure the tool length wear along its shaft.</li> <li>• Calibrate the length or measure the tool length wear on its tip.</li> <li>• Calibrate the radius or measure the radius wear of a tool.</li> <li>• Calibrate the radius and the length or measure the radius and length wear of a tool.</li> </ul> <p><i>To select the desired one, position over the desired icon and press the (a) key.</i></p>
S	Tool turning speed.
	Tool turning direction. Select the direction opposite to the cutting direction. <p><i>To select the desired one, position over the desired icon and press the (a) key.</i></p>
N	Number of cutting edges of the tool to be measured.
X+	In radius calibration and measurement, it indicates the side of the probe to be used: (X+) (X-) (Y+) (Y-). <p><i>To select the desired one, position over the desired field and press the (a) key.</i></p>



NEW FEATURES

(SOFT M: 7.xx)

MC model. Tool measurement and calibration

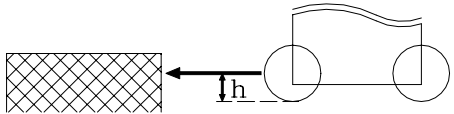
d	When the length calibration or measurement is done on the tip, it indicates the radius or distance with respect to the tool shaft being probed.
h	When calibrating the radius, it indicates the distance referred to the theoretical tool tip being probed. It is very useful with cutters whose bottom is not horizontal.  

The [S, N, X+, d and h] fields are requested when the Calibration/ Measurement (A) method so requires.



Zone (2) defines whether a Measurement or a Calibration is to be carried out. To select the desired one, position over the desired "Measurement / Calibration" field and press the (a) key.

A measurement requires the optional "tool life monitoring" and the following fields must be defined:

Kmax	Maximum length wear allowed.
Imax	Maximum radius wear allowed.
Stop	Behavior when exceeding the maximum wear allowed
Chg	Stop - It interrupts the execution for the user to select another tool. Chg - The cycle replaces the tool with another one of the same family. <i>To select the desired one, position over the desired field and press the (a) key.</i>

Zone (3) defines the probe coordinates. Indicate whether the CNC must assume the machine parameter values or the ones set in this zone. To select the desired one, position in the "Machine Parameters / Programmable Parameters" field and press the (a) key.



NEW FEATURES

(SOFT M: 7.XX)

MC model. Tool measurement and calibration





## 1 Detected errors

### A.m.p. DFORMAT (P1)

The installation manual shows wrong work units. The right work units are:

Value	Work units	Format in degrees	Format in mm	Format in inches
0	radius	5.3	5.3	4.4
1	radius	4.4	4.4	3.5
2	radius	5.2	5.2	5.3
3	radius	It is not displayed		
4	diameters	5.3	5.3	4.4
5	diameters	4.4	4.4	3.5
6	diameters	5.2	5.2	5.3

### Connector X4. To connect the analog spindle (8055i model)

The installation manual shows the wrong function associated with pins 11 and 12. The right pin values are:

Pin	Signal and Function	
	1	Ac
2	/ Ac	
3	Bc	
4	/ Bc	
5	I0c	
6	/ I0c	
7	ALc	
8	/ ALc	
9	+5 V	+5V output for feedback
10	ConsCab	Analog voltage output
11	GND	0V output for feedback
12	GND	0V output for the analog voltage
13	----	
14	----	
15	Chassis	Shield

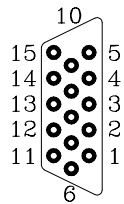

It admits TTL and differential TTL feedback.

### Connector X5. To connect electronic handwheels (8055i model)

It admits TTL and differential TTL feedback.

### Connector X10, X11, X12 and X13. Feedback inputs for the axes (8055i model)

It admits 1Vpp, TTL and differential TTL feedback.

**Connector X2. I/O module (8055 model).**

The installation manual indicates that input I65 is assigned to pin 1. Actually, input I65 is assigned to pin 2. The right pin values are:

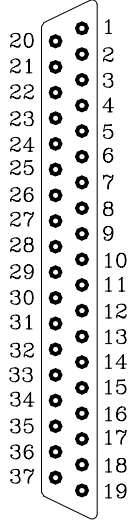
	Pin	Signal and Function	
	1	-----	
	2	I65	
	3	I67	
	4	I69	
	5	I71	
	6	I73	
	7	I75	
	8	I77	
	9	I79	
	10	I81	
	11	I83	
	12	I85	
	13	I87	
	14	I89	
	15	I91	
	16	I93	
	17	I95	
	18	0V	External power supply
	19	0V	External power supply
	20	-----	
	21	I66	
	22	I68	
	23	I70	
	24	I72	
	25	I74	
	26	I76	
	27	I78	
	28	I80	
	29	I82	
	30	I84	
	31	I86	
	32	I88	
	33	I90	
	34	I92	
	35	I94	
	36	I96	
	37		Chassis - Shield

**Connector X3. RS232 serial line (8055 model)**

**Connector X1. RS232 serial line (8055i model)**

From this version on, pin 9 no longer supplies 5V.

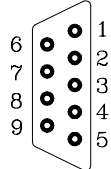
	Pin	Signal
	1	DCD
	2	RxD
	3	TxD
	4	DTR
	5	GND ISO
	6	-----
	7	RTS
	8	CTS
	9	-----



NEW FEATURES

(SOFT M: 7.1X)

Detected errors



## Variables POS(X-C) and TPOS(X-C)

The values of variables POS(X-C) and TPOS(X-C) are in the following units.

- They are read from the CNC in radius or diameter depending on the setting of a.m.p. "DFORMAT (P1)".
- They are always read in radius from the PLC.

## Pockets programming examples

The programming examples for rectangular and circular pockets set variables "TOR1=6 and TOT1=0". The right variables to be defined are "TOR1=6 TOI1=0"

## I/O board (8055 model)

The fuse of the I/O board has been eliminated.

## Improved real block processing time calculation for look-ahead

The value of g.m.p "TLOOK" is calculated as follows:

Execute, in G91 and G51 E0.1, a program with many small blocks, at least 1000. For example: "X0.1 Y0.1 Z0.1".

Measure the program execution time, making sure that the machine does not vibrate. Divide the execution time by 1000 (or the number of blocks executed) and assign the resulting value, in microseconds, to g.m.p. "TLOOK (P161)".

To optimize this parameter, decrease the calculated value and execute the same program until the machine starts vibrating. In order not to damage the machine, we recommend to begin with the override switch low and increase its value gradually.

We recommend the use of the oscilloscope function and verify that the internal variable VLOOKR remains constant which means that there is no vibration. When configuring the oscilloscope, it is possible to change g.m.p. "TLOOK", but the new value is only assumed when executing the G51 function via program.



NEW FEATURES

(SOFT M: 7.1X)

Detected errors

## 2 New validation codes

Due to new software options, the validation code changes from 16 to 24 characters. The new codes are also valid for the Memory Cards with software versions older than V7.11

## 3 Smooth stop in probing move (G75/G76)

From this version on, a smooth stop may be defined for probing moves. When the probe pulse is detected, the following error is not reset, thus making the probe stop more smoothly.

**PROBEDEF (P168)** It defines the type of stop for the probing moves. It has 16 bits. Bit 16 selects the selected type of stop.

PROBEDEF xxxx xxxx xxxx xxx 0/1

- 0 Standard Stop.
- 1 Smooth stop.

By default 0

When setting the smooth stop, a.m.p "DERGAIN (P25)" and s.m.p. "FFGAIN (P25)" should be set to zero. This may be done by setting the range of gains through g.m.p. "ACTGAIN2 (P108)" with the bit corresponding to G75/G76.

## 4 Square-corner or round-corner machining when changing tool offset

When executing a tool change, the change takes place at the end of the path. Using g.m.p. "TOOLTYPE (P167)" it is possible to define how to machine the corner where the tool offset is being changed. This corner may be machined in square corner (sharp) or rounded.

This parameter is only taken into consideration when working in round corner. When working in square corner, the corner is always machined in square corner mode.

**TOOLTYPE (P167)** It has 16 bits. Bit 2 selects the type of corner.

TOOLTYPE x 0/1 xx xxxx xxxx xxxx

- 0 Square corner.
- 1 Round corner.

By default 0



NEW FEATURES

(SOFT M: 7.1X)

New validation  
codes

## 5 New management of the distance-coded reference mark (I0)

From this version on, the distance-coded I0 via SERCOS may be managed using the input of the drive's second feedback.

- The axis parameters to define the distance-coded I0 are at the CNC.

I0TYPE (P52)	I0CODI1 (P68)	I0CODI2 (P69)
ABSOFF (P53)	REFDIREC (P33)	REFEED2 (P35)
AXISCHG (P16)	LOOPCHG (P26)	

We recommend to set axis parameter POSINREF=NO. Otherwise, it generates a movement to the position defined by axis parameter REFVALUE.

- The parameters related to the counting of pulses (feedback) are at the drive. At FAGOR drives, the parameters are:

GP10	Feedback2Type
NP117	ResolutionOfFeedback2
NP118	ResolutionOfLinearFeedback
PP115.0	PositionFeedback2Type

The drive version must be V4.10 or V5.10 ( or greater).

## 6 Improved look ahead

Machining feedrate variations are now smoother thanks to filtered acc/dec in short movements.

## 7 Leadscrew error compensation in both directions

### Bidirectional leadscrew error compensation

From this version on, it is possible to define a different leadscrew compensation for each moving direction.

This is defined in the leadscrew compensation tables. Each row of the table contains the following data:

- The position of the axis to be compensated.
- The amount of error of the axis at that point. In the positive direction.
- The amount of error of the axis at that point. In the negative direction.

For each axis position, define the amount of error to compensate in both directions. If the error in the negative direction has a zero value in all positions, it is assumed that the error defined for the positive direction is valid for both directions.

Likewise, the compensation defined in a single direction or for both, the compensation error at the reference point does not need to be zero.



NEW FEATURES

(SOFT M: 7.1X)

**New management  
of the distance-  
coded reference  
mark (I0)**



*Software compatibility with respect to version V7.11:*

- *When updating from a version older than V7.11.  
It maintains the values of the error in the positive direction of the tables and assigns a zero error in the negative direction to all the points.*
- *When changing to a version older than V7.11.  
It maintains the error values in the tables in the positive direction, but it loses the ones in the negative direction.*

## 8 Parameters accessible from the oscilloscope or OEM subroutine

### 8.1 Axis parameters that may be modified from the oscilloscope

The following axis machine parameters may be modified.

Indicate the axis and the parameter number separated by a dot.  
Example: [X.P18], [Z.P23].

Number	Parameter	Update
P42	MAXFEED	Beginning of the next block
P43	JOGFEED	Beginning of the next block

### 8.2 General parameters modifiable from the oscilloscope

The following general machine parameter (needed to adjust the machine) may be modified from the oscilloscope.

Enter the indicator of the general parameter and the parameter number separated with a dot. Example: [G.P161].

Number	Parameter	Update
P161	TLOOK	Beginning of the execution of a program.

### 8.3 Machine parameters modifiable from an OEM program

All the parameters modifiable from the oscilloscope can also be changed from an OEM program using the following variables.

MPGn	MP(X-C)n	MPSn
MPSSn	MPASn	MPLCn

The new values are updated according to the tables described in chapter [32 Oscilloscope function](#). It is not necessary to press [RESET] or [SHIFT]+[RESET] to update the values.



NEW FEATURES

(SOFT M: 7.1X)

Parameters  
accessible from the  
oscilloscope or  
OEM subroutine





CNC 8055 / CNC 8055I



**FAGOR** 

REF. 0504

(SOFT M: 9.0x)

(SOFT M: 9.1x)

**NEW FEATURES**

Ref. 0504

(Soft M: 9.0x) (Soft M: 9.1x)





# INDEX

Version V9.01

1	New hard disk and Ethernet .....	1
1.1	Configuration .....	3
1.2	Modified variables .....	5
1.3	Modified programming instructions .....	5
1.4	Hard disk diagnosis .....	6
1.5	Diagnosis of the Ethernet configuration .....	7
1.6	Connection to a PC through WinDNC .....	8
1.7	Connection to the network through FTPserver.....	9
1.8	Format of the program.....	11
2	CARDA slot as floppy disk drive .....	12
3	Telediagnosis .....	14
3.1	Disable the CNC screen and keyboard from the PC .....	14
3.2	Telephone call from the CNC .....	14
4	Tandem axes .....	15
4.1	Block diagram.....	16
4.2	Control of the tandem axis .....	17
4.3	Machine parameter setting.....	20
4.4	Variables .....	22
4.5	Tandem adjustment.....	22
5	Incline axis management .....	25
6	Additive coupling between axes.....	28
6.1	Configuration .....	29
6.2	PLC program .....	29
7	TCP management on rotary table .....	30
8	Tool change .....	33
8.1	Stop block preparation when executing a new T.....	33
8.2	New treatment of CYCLE STOP during the execution of a T.....	33
9	Modification of the operation of the feedrate when it is F0.....	34
10	The cross compensation on gantry axes affects the slave axis .....	34
11	Subroutines associated with M41, M42, M43, M44 .....	35
12	Probe input selection.....	35
13	Programming in radius or diameter .....	35
14	Program G2 and G3 without the center coordinates (I, J, K) .....	36
15	Changing the kinematics by program.....	36
16	Modifications in PLC operation .....	36
16.1	Initializing the PLC outputs while compiling the program .....	36
16.2	Ending the execution of a block using a PLC mark.....	37
16.3	"Rapid" key controlled by PLC in execution and simulation .....	38
16.4	Name the logic inputs and outputs with the axis name .....	39
17	New marks to park spindles .....	39
18	Modifications and new variables .....	40
19	Parameters accessible from the oscilloscope or OEM subroutine.....	41
20	MC model. ISO programming assistance .....	41
20.1	Zero offsets and presets.....	42
20.2	Work zones .....	42
20.3	Place labels and repetitions from label to label .....	43
20.4	Mirror image .....	43
20.5	Scaling factor.....	43
20.6	Coordinate rotation .....	44
21	MC model. Zero offset table management.....	44
22	MC model. Accessing cycles and programs from the auxiliary screen .....	45
23	MC model. In case of error in a cycle, point to the erroneous cycle. ....	45
24	MC model. Display name and number of the cycle.....	45
25	MC model. Highlighting the axis being moved in jog or with handwheels.....	46
26	MC model. Copying a profile.....	46
27	MC model. Select a program by indicating its number.....	46

28	MC model. Selection of the reference point in rectangular pockets and bosses. ....	47
29	MC model. Multiple machining in pockets and bosses .....	47
30	MC model. Configuration of two and half axes .....	49
30.1	Configuration .....	50
30.2	PLC program .....	51
31	OEM cycles. Copying a profile .....	53

## Version V9.11

1	Detected errors .....	55
2	Heat dissipation. Central Unit enclosure .....	56
2.1	Heat dissipation by natural convection .....	57
2.2	Heat dissipation by forced convection with inside fan .....	57
2.3	Heat dissipation by air flow to the outside using a fan .....	58
3	Can regulation .....	59
3.1	Configuration at the 8055 CNC .....	59
3.2	Configuration at the 8055i CNC .....	59
3.3	Can transmission speed selection .....	61
3.4	Can address selection .....	61
3.5	Communication levels via Can .....	62
3.6	Spindle gears with Can regulation .....	62
3.7	Setting the feedback resolution of the axes .....	63
3.8	Communication channels via Can .....	63
3.9	Axis management via Can .....	64
3.10	Limitations of Can axes .....	67
3.11	CNC logic inputs and outputs via Can .....	67
4	8055 model. VPP axes module .....	70
4.1	Connectors and connection .....	71
4.2	Technical specifications .....	77
4.3	Configuration. Machine parameters .....	78
4.4	Modified variables .....	78
5	8055i model. New axis board .....	79
5.1	Modified variables .....	79
6	Hardware associated with the compact flash .....	79
7	Automatic keyboard type identification .....	80
8	Sharing the CNC's hard disk with password via FTP .....	81
9	Improved telediagnosis .....	82
9.1	Telediagnosis through the Internet .....	82
9.2	Advanced direct telephone call .....	83
9.3	Disconnecting the CNC from the Ethernet network during telediagnosis .....	87
10	Modified variables .....	88
11	Changes in tool radius compensation .....	89
11.1	Change of type of compensation (G41-G42) while machining .....	89
11.2	New tool radius compensation modes. ....	90
11.3	Improvements in tool radius compensation .....	92
12	Improved retracing .....	93
13	Improved Look-Ahead. It allows G74, G75 and G76 .....	93
14	Keep G46 while searching home. ....	93
15	New MEXEC instruction .....	94
16	Accessing the variables of the auxiliary spindle drive from the oscilloscope. ....	94
17	Manual intervention with additive handwheel .....	95
18	Frequency filters .....	97
18.1	Machine parameters for defining the filters .....	98
19	Parameter to set the maximum feedrate in rapid .....	99
20	Sercos transmission speed at 8 Mhz and 16 Mhz .....	100
21	New range of G functions .....	100
22	DNC communication status .....	100
23	The motionless simulation ignores G4 .....	100
24	Status of the timer programmed with G4 .....	101
25	Maintain the last F selected in simulation .....	101
26	Parameters accessible from the oscilloscope or OEM program .....	101
27	Controlled braking of spindle and axes via Sercos in case of an emergency at the CNC101	
28	New coordinate variables APOS and ATPOS .....	101



NEW FEATURES

1	Hirth axis pitch may be set in degrees via parameters .....	103
2	Rollover positioning axes. Movements in G53 via the shortest way .....	103
3	New "Sercos II" transmission board .....	104
3.1	New Sercos power table .....	104
3.2	Set the transmission delay at the bus for transmissions at 8 Mhz and 16 Mhz.....	104



NEW FEATURES



## 1 New hard disk and Ethernet

This version and the newer ones offer the following hardware options. Both options are enabled with their corresponding software options.

- Mechanical or compact-flash type hard disk.
- Ethernet.

When having the hardware but the software option is disabled, the new hardware will not be operational. The hardware configuration window does show it.

### Particularities at the 8055 CNC

The hard disk and the Ethernet connector are integrated into the CPU module. Until now, this configuration was located in the Hard Disk module. When using the new hardware with these options, disable the Hard Disc module regardless of the software options. In this case, it shows a message informing about this situation. The old Hard Disc module will appear on the hardware configuration window.

When having the new hardware, the software options are ignored and the Hard Disk module stays enabled.

### Ethernet

The Ethernet option permits configuring the CNC as another node within the local area network. This makes it possible to communicate with other PC's to transfer files or carrying out telediagnostic tasks.

Once the connection to Ethernet has been configured, the following types of connections are possible:

- Connection to a PC through WinDNC.
- Connection from a PC through an FTP client.
- Connection to a remote hard disk.

The Ethernet card has an RJ-45 connector and two LED's that inform on the status of the connection.

Red LED    Blinks while transmitting data.

Green LED    On while connected to the network.

Use a standard shielded 10BASE-T cable for this connection. It must not be longer than 100 meters.



---

*The WinDNC that supports Ethernet is V4.0 or newer.*

*Ethernet does not require having the DNC option available.*

---



NEW FEATURES

(SOFT M: 9.0x)

## Hard disk

It is possible to use a local hard disk at the CNC itself or a remote hard disk accessible through Ethernet. The remote hard disk does not require having the DNC option.

### Local hard disk

#### ■ 8055 model

A mechanical hard disk of 20 Gb is integrated into the CPU module. Optionally, a compact flash type hard disk may be installed that can be accessed from the outside.

#### ■ 8055i model

Compact flash type disk, not accessible from the outside.

### Remote hard disk

The Ethernet connection may be used to use a PC directory (server) as a hard disk. This memory space may be shared by several CNC's or each may have its own memory space.

The interface and the softkeys of the CNC will be the same as if it were a local hard disk. When accessing the CNC through WinDNC or FTP, the remote hard disk behaves like a local hard disk.

The remote hard disk is configured by machine parameters. The PC that makes its hard disk (server) public must be connected to the local network.



---

*The NFS protocol is used to communicate with the remote hard disk.  
This protocol must be available at the PC that is used as server.*

---

## 1.1 Configuration

### CNC configuration like another node in the network

**HDDIR (P0)** Not being used.  
**CNMODE (P1)**

**CNID (P2)** CNC's name. When connecting through FTP (only with some FTP clients).

---

*Possible values:* It admits up to a maximum of 15 characters (without blank spaces).

*By default:* FAGORCNC

---

**CNGROUP (P3)** Not being used.

.....

**SERUNI2 (P21)**

**DNCEACT (P22)** DNC number to be used by Ethernet.

All three communication devices (serial lines 1 and 2, and Ethernet) cannot be active. In order to use Ethernet, one of the serial lines must be disabled.

---

*Possible values:*

- 0 There is no active DNC associated with Ethernet.
- 1 DNC 1 associated with Ethernet. The RS-422 serial line is disabled.
- 2 DNC 2 associated with Ethernet. The RS-232 serial line is disabled.

*By default:* 1

---

**IPTYPE (P23)** Reserved. It must be set to "0".

**DIRIP (P24)** CNC's IP address.

---

*Possible values:* Four numbers between 0 and 255 separated by dots.

*By default:* 0.0.0.0 (the network is not activated).

---

Implies [SHIFT]+[RESET].

**NETMASK (P25)** Network mask.

---

*Possible values:* Four numbers between 0 and 255 separated by dots.

*By default:* 0.0.0.0

---

Implies [SHIFT]+[RESET].

**IPGATWAY (P26)** Gateway IP address.

---

*Possible values:* Four numbers between 0 and 255 separated by dots.

*By default:* 0.0.0.0 (it has no gateway).

---

Implies [SHIFT]+[RESET].



NEW FEATURES

(SOFT M: 9.0x)

## DNC configuration for Ethernet

**IPWDNC (P27)** WinDNC server's IP address. The WinDNC server is the external device to connect with via DNC. This device may be a CNC, or a PC with WinDNC.

Defining it as 0.0.0.0 does not allow transferring from the CNC, but it is possible from the PC.

<i>Possible values:</i>	<i>Four numbers between 0 and 255 separated by dots.</i>
<i>By default:</i>	<i>0.0.0.0</i>

Implies [SHIFT]+[RESET].

## Configuration of the remote hard disk

The Ethernet connection may be used to use a PC directory (server) as a hard disk. The NFS protocol is used to communicate with the remote hard disk. This protocol must be available at the PC that is used as server.

**IPSNFS (P28)** IP address of the server acting as remote hard disk.

If other than 0, the remote hard disk is activated. This means that the local hard disk, if there is any, is disabled and can no longer be accessed.

<i>Possible values:</i>	<i>Four numbers between 0 and 255 separated by dots.</i>
<i>By default:</i>	<i>0.0.0.0 (there is no remote hard disk)</i>

Implies [SHIFT]+[RESET].

**DIRNFS (P29)** Directory of the server that is used as remote hard disk.

<i>Possible values:</i>	<i>It admits up to a maximum of 22 characters (without blank spaces).</i>
<i>By default:</i>	<i>Nameless.</i>

Implies [SHIFT]+[RESET].

## Configuration of the Ethernet connection

**MACID (P30)** Reserved. It must be set to "0".

**ETHEINLE (P31)** Not being used.



NEW FEATURES

(SOFT M: 9.0x)



## 1.2 Modified variables

**HARCON** It indicates, with bits, the CNC's hardware configuration. The bit will be "1" when the relevant configuration is available.

8055 CNC model:

Bit	Hardware
29	Hard disk integrated into the CPU.
30	Ethernet integrated into the CPU.
31	Compact flash.

8055i CNC model:

Bit	Hardware
30	Ethernet.
31	Compact flash.

**HDMEGA** Hard disk size in megabytes.

**MEMTST** HD test result. Bit 8 will be set to "1" if the test is OK and it will have another value if there is an error.

## 1.3 Modified programming instructions

### "OPEN" instruction.

When programming the OPEN instruction, the target directory is selected as follows:

CARDA	in the "Memkey Card".
HD	in the Hard Disk.
DNC1	in a PC connected through serial line 1.
DNC2	in a PC connected through serial line 2.
DNCE	in a PC connected through Ethernet.

## 1.4 Hard disk diagnosis

From the diagnosis mode, it is possible to test the local or remote hard disk. This operating mode is accessed from Diagnosis >Tests> Hard disk.

Accessing this screen runs a test on the disk. Testing the hard disk includes a test of the surface. This test is not carried out on a remote hard disk and the relevant message is displayed.

When detecting an error, it shows the relevant error message at the bottom of the window.

DIAGNOSIS		P..... N....		DNC		12:24:55	
<b>HARD DISK TEST</b>							
<b>PHYSICAL</b>				<b>LOGIC</b>			
Model	* * *			Block size	4096 Bytes		
Physical	984	16/	32	Total blocks	62846		
Logic	984	16/	32	Free blocks	40150		
<b>MOUNTING</b>				Occupied blocks	22696		
Ok				Sector/Cluster	8		
				Label	BCB		
Ok						CAP INS	

This mode shows the following information:

- Physical information.  
Hard disk model installed and information on the physical and logic partition (cylinders, heads and sectors). The physical and logic partitions might not be the same.  
This information is only displayed for the local hard disk. When having a remote hard disk, this information is not available.
- Logic information.  
Size in bytes of each of the blocks the disk is divided into. Total number of blocks in the disk, free and occupied. Number of sectors in a cluster.  
The label is the name given to the disk when formatting it.
- Mounting information.  
If no error occurred, it shows the message "OK".  
Local hard disk: In case of error, it indicates the error number and the mounting stage where it came up.  
Remote hard disk: In case of error, it only shows a message indicating the type of error.



NEW FEATURES

(SOFT M: 9.0x)

## 1.5 Diagnosis of the Ethernet configuration

From the diagnosis mode, it is possible to check the status of the Ethernet configuration. This operating mode is accessed from Status> Ethernet.

ETHERNET		P..... N....		DNC		12:24:55	
NET							
MAC	00:0B:CB:10:00:10	MASK	255.255.0.0				
DIRIP	10.0.17.70	GATEWAY					
RECEPCION							
Packs	767	Errors	0	Lost	0		
Overrun	0	Frame	0				
TRANSMISION							
Packs	1980	Errors	0	Lost	0		
Overrun	0	Collisions	1	Carrier	0		
FTP Active							
REMOTE HARD DISK		Active					
						CAP	INS

- The top of the screen shows the network configuration (MAC or Ethernet address, IP address, network mask and the IP address of the gateway).  
When detecting an error in the configuration, it will show the corresponding error message.
- The mid area of the screen shows the information on data transmission and reception. With a green background the fields that must be 0 when working fine.
- The bottom of the screen shows the data of the active services. For the remote hard disk, it shows the IP address and the shared directory. If there is no remote hard disk or there is an error, it shows the corresponding error message.

## 1.6 Connection to a PC through WinDNC

The PC operative system must be Windows® and it must have the WinDNC software (V4.0 or newer). The CNC must be configured just like another node within the local network or internet.

Possible connections:

- From a PC

The connection may be initiated at any PC and addressed to any CNC. Two PC's cannot be connected to each other.

To establish the connection, the WinDNC allows the user to enter the CNC's IP address to be used for the connection.

- From a CNC

The connection is always addressed to the DNC server. The DNC server is defined in the machine parameter "IPWDNC".

As with the serial lines, the DNC status screen shows its status through Ethernet. Also, the connection may be activated and deactivated from the softkey menu. When having the DNC available, the top of the screen shows the message " DNC E".

It is possible to connect several WinDNC (up to 10) simultaneously to the same CNC. The access protection is by operation. If several WinDNC initiate an operation, the commands are processed one by one while the rest of the WinDNC's wait.

## 1.7 Connection to the network through FTPserver

The FTP protocol permits transferring files between a PC and a CNC connected to a local network or to internet. The FTP client, in charge of managing the transfer, must be installed at the PC. The interface depends on the FTP client being used.



*The PC operative system may be Windows, Linux or Unix.*

*Windows® includes an FTP client in its Internet Explorer application from version 5.x on. From Windows® version 98 on, the windows explorer has its own integrated FTP client.*

The CNC must be configured just like another node within the local network or must have an internet connection. For that, it must have the Ethernet option.

From the PC, it is possible to access the CNC by knowing its IP address. Only the hard disk of the CNC may be accessed. In other words, it won't be possible to access the RAM or CARDA nor read variables, tables, etc. The CNC files cannot be modified directly either. First copy them to the PC, modify them and copy them to the CNC.

When accessing the CNC from a PC via FTP, it shows the following directory structure.

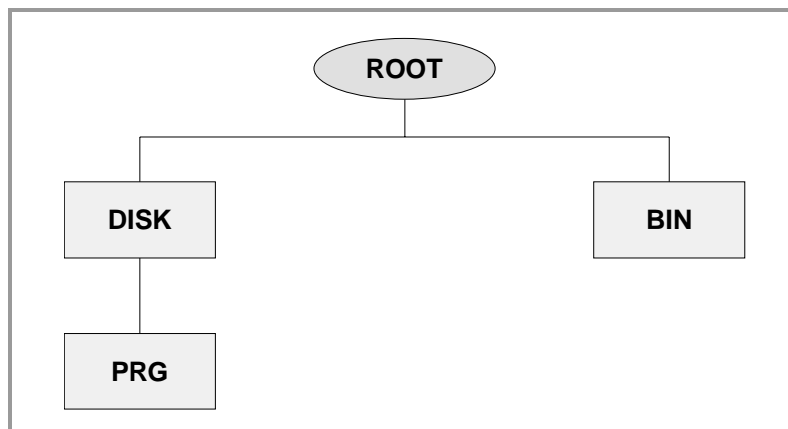

- BIN** System folder used by the FTP protocol. It cannot be modified.
- DISK** CNC hard disk. The user can fully access it from the PC. Although subdirectories and files may be defined, they won't be accessible from the CNC.
- PRG** Part-programs and PLC programs stored at the CNC. If this folder does not exist on start-up, an empty one is created.

Although the user may create new directories through the FTP, only the programs contained in the "PRG" directory may be seen from the CNC.

If the CNC does not have a hard disk, it will show the directory empty and it will not allow sending any program.

## Connection using Windows® 95 or 98.

### Entering the IP address directly

At the Web explorer or from the file explorer (only on Windows 98), write in the command line the CNC's IP address. For example, `ftp://10.0.7.224`.

### Assigning a name to the IP address

There are two ways to assign a name to the IP address.

- In the "c:\windows\hosts" file, add a line containing the CNC'S IP address and the name to identify it with. This file may be modified with any text editor.

For example:

```
10.0.7.40    CNC_1
10.1.6.25    MILL_MACH_01
```

At the Web explorer or from the file explorer (only on Windows 98), write the defined name in the command line. For example, `ftp://CNC_01`.

- In the Web explorer, write the IP address in the command line. After accessing the site, select from the menu, the option: Favorites> Add to favorites. It shows a dialog box to assign a name to that IP address.

This way, it is possible to access the CNC by selecting the assigned name on the "Favorites" menu.



*It appears as "Favorites" on the Internet Explorer. This name may vary depending on the Web explorer being used.*

## Connection using Windows® 2000 or XP.

At the file explorer, select Network> Add network sites. It will then show a series of dialog boxes where the following data must be defined.

1. CNC's IP address.
2. Type of beginning for an anonymous FTP session or not. In this case, select the beginning of an anonymous session.
3. The name to be associated with the IP address of the CNC.

The next time the network directory is accessed, it shows the CNC with the defined name. Just select the CNC from the list to establish the connection.

## File transfer

To copy a file from the PC to the CNC.

- In any Windows® (95, 98, 2000 or XP) system.  
Drag the file from one folder to another or use the keyboard shortcuts [CTRL]+[C] and [CTRL]+[V].

To copy a file from the CNC to the PC.

- In Windows® 95 or 98.  
Click the right mouse button on the file, select the option to "Copy to folder" and select the destination folder.
- In Windows® 2000 or XP.  
Drag the file from one folder to another or use the keyboard shortcuts [CTRL]+[C] (copy) and [CTRL]+[V] (paste).



NEW FEATURES

(SOFT M: 9.0x)

## 1.8 Format of the program

Programs generated by the user at a PC and transferred to the CNC must have the standard format of the CNC.

### Program name

- For part-programs, the name has 6 digits. The file extension must be PIT for lathe programs or PIM for mill programs.

```
123456.pit      345923.pim
045683.pit      456793.pim
```

- For PLC programs, the name must be PLC\_PRG, PLC\_MSG or PLC\_ERR. The file extension must be PIT for lathe programs or PIM for mill programs.

```
Plc_prg.pit      Plc_prg.pim
Plc_err.pit      Plc_msg.pim
```

If the CNC contains programs whose names do not match with this format, those files will not be displayed at the CNC.

### Comments and permissions

To display comments and permissions, the format of the first line of the program must be:

```
%COMMENT, PERMISSIONS
```

The "%" character followed by the comment and the permissions. The comment may have up to 20 characters and the permissions must be defined by the letters MXHO in any order.

---

M	Modifiable program.
X	Executable program.
H	Visible program.
O	OEM program.

---

If this line is not defined in the file, when displayed at the CNC, it will not show any comments and the attributes shown will be MX.

If the first line begins with a "%", but it does not have a valid format, it will be interpreted as having <\*\*\*\*\*> for a comment and its permission will be "M" (may be modified but not executed).

## 2 CARDA slot as floppy disk drive

From this version on, it is possible to use the slot of the memkey card (CARDA) as a floppy disk drive. As a storing device, use either Fagor memory cards or standard off-the-shelf cards "INTEL series 100". Memkey cards cannot be used as storage devices.

Only part-programs and PLC message and error programs may be stored in the memory card.

Next, a description on how to copy a program from a PC to the CNC. The inverse operation, from the CNC to the PC is done in a similar way.

- At the PC. Copy the programs in the memory card using the WinDNC.
- At the CNC. Remove the memkey card and insert the memory card. Copy from CARDA the program or programs into the memory or the hard disk of the CNC.
- At the CNC. Remove the memory card and insert the memkey card back in order to be able to execute. "Cycle Start" has no effect if the memkey card has not been inserted. In other words, it is not possible to execute directly from the memory card. The CNC with the memory card in will remain in minimum configuration as if there were nothing in the slot for CARDA.

The memory card may be inserted and extracted from the CNC while the CNC is on.

The memkey card cannot be extracted (removed) while in execution if it is being accessed; in that case, the corresponding error will be issued. For example, if it is executing from CARDA, it is displaying screens from CARDA, etc.

### Restrictions of the memory card

In order to be able to read or write on a memory card, it must be formatted in Fagor mode. This operation may be carried out at the CNC from the mode: "Diagnosis" -> "Tests"-> "Format CARDA". If a memkey card has been inserted, it does not show the formatting option. At the PC, the memory card may be formatted using WinDNC.

When powering up the CNC with a memory card in, it considers it invalid and it issues an error indicating minimum configuration. On the other hand, that memory card will not be recognized as such until it is extracted from the CNC and inserted back.

At the CNC, the software configuration screen shows the card's hardware ID. If a floppy disk type memory card is inserted, the ID will be FFFFFFFE.



NEW FEATURES

(SOFT M: 9.0x)



## Functionality at the PC via WinDNC

In order to be able to read and write onto these memory cards from a PC so the CNC understands it, meet the following requirements:

- WinDNC version V4.0 or newer.
- Operative system: Windows® 2000 or XP.
- PCMCIA slot.

The list of the possible WinDNC connections will show the CARDA option. When connecting to the CARDA, it checks the slot of the PCMCIA and it acts as follows:

- There is no memory card inserted.  
The interface warns about it and the connection fails.
- There is a memkey card inserted.  
The interface warns about it and the connection fails.
- The inserted memory card is correct.  
Connection is established.
- There is a memory card, but it is not formatted.  
It offers the user the chance to format it. When accepting to format it, everything is fine and the connection is established. If the formatting is canceled or a problem occurs while formatting, the interface warns about it and the connection fails.
- There is some other problem (maybe hardware related or that has to do with the driver configuration).  
The interface shows an error message and the connection fails.

Once the connection has been established, it is possible to access the "Files" menu. The options to see tables, symbols and screens are disabled. Only part-programs and PLC programs may be manipulated. These may be transmitted from and to the memory card. On the contrary, tables, symbols, screens and parameters cannot be manipulated.

When copying programs with the memory card, it maintains the OEM permissions and the "hidden" file attribute.

### Considerations

Before extracting the memory card from the PC, finish the WinDNC connection.

### 3 Telediagnosis

#### 3.1 Disable the CNC screen and keyboard from the PC

The CNC screen and keyboard may be disabled from the WinDNC so the user cannot manipulate the CNC while telediagnosis is running.

When the keyboard is disabled, neither the feedrate override nor the CYCLE STOP button are disabled. These operations are carried out by activating and deactivating the corresponding icons on the left side of the telediagnosis screen.

#### 3.2 Telephone call from the CNC

A screen will come up at the CNC for dialing a telephone number through a modem. This screen is accessed from "DNC status", by pressing the "telephone call" softkey.

The screen allows entering a telephone number indicating the line access, country code, number and extension.

If the "telephone number" field has already a value, it is possible to make a call by selecting the telephone icon and pressing [ENTER] or by pressing the "Call" softkey. Likewise, to pick it up, it may be done using the icon or the "pick up" softkey.

It is also possible to select the call by pulses or by tones by selecting the corresponding window.

The bottom of the screen shows the warning and error messages that come up.

To establish connection, the WinDNC of the PC must be in the new call waiting mode.

## 4 Tandem axes

An tandem axis consists in two axes coupled mechanically making up a rack-and-pinion system and driven by two different motors. It is normally used to move the axes on large machines.

There are two aspects to point out in this type of configuration:

- A tandem axis permits using the necessary torque to move an axis when a single motor is not capable of providing enough torque to do it.
- Applying a pre-load torque between the main motor and the slave motor reduces the backlash of the rack-and-pinion system.

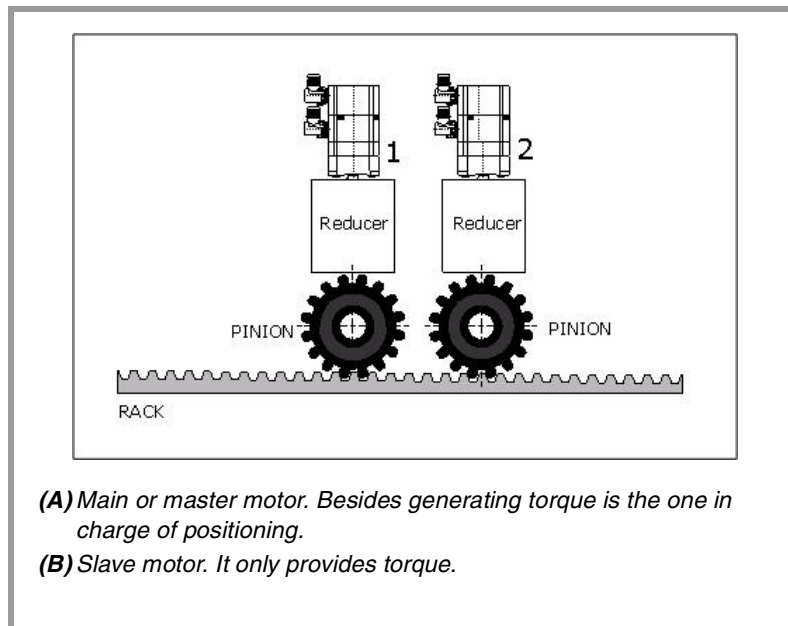

One of the many applications for the control of a tandem axis has to do with gantry machines.

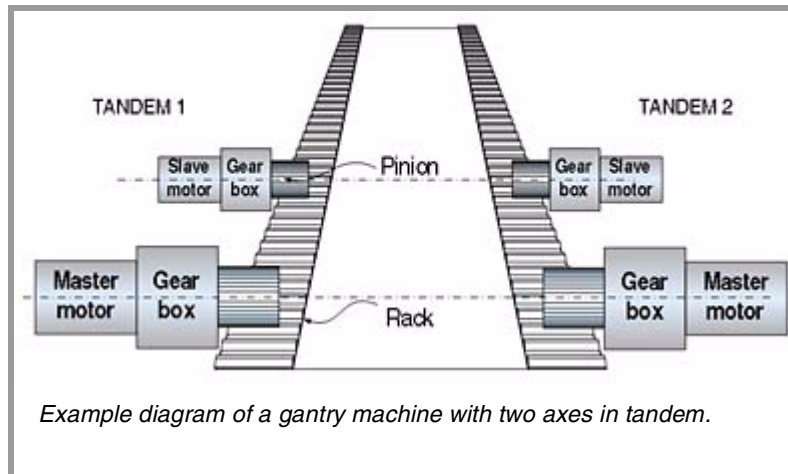

## Prior considerations

Bear in mind that:

- Each tandem master axis can only have one tandem slave axis.
- A pre-load may be applied between both motors.
- Each motor may have a different rated torque.
- Each motor may be rotating in the opposite direction to the other one.
- The torque distribution between both motors may be different from a 1:1 ration. For example on motors with different rated torques.
- It is not possible to share feedback or velocity commands using the switch parameters on axes having a tandem configuration.

## 4.1 Block diagram

The block diagram of the tandem control system shows the tandem master axis with its tandem slave axis.

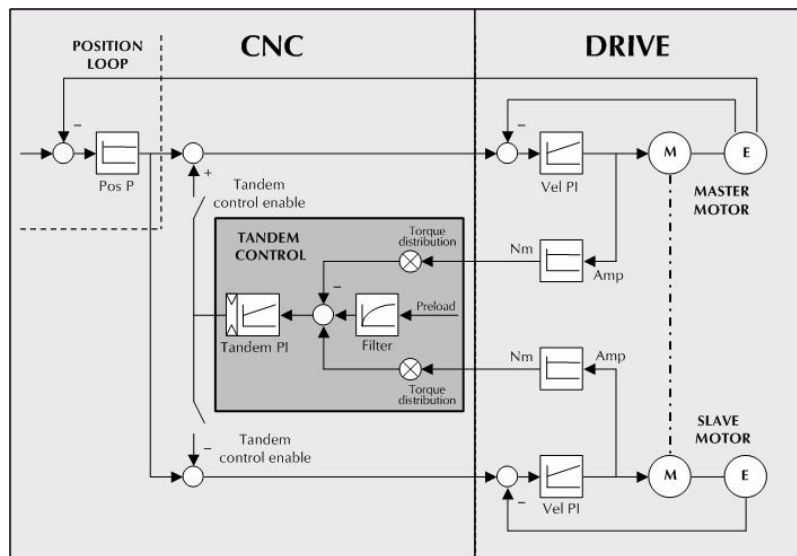

The block diagram for a gantry machine consists of the same two diagrams as the one shown in the figure.

### General description. Position and velocity loops.

The block diagram shows an area for the drive and another one for the CNC that covers the position loop and the control of the tandem.

- The position loop only closes with the position of the master axis of the tandem. The velocity command of the tandem master axis is sent to the tandem slave axis closing the velocity loop.
- The tandem control modifies the velocity command of the master axis and of the slave axis depending on the torque distribution and the selected pre-load.

The PROGAIN, FFGAIN and DERGAIN values of the master axis are applied to the slave axis.

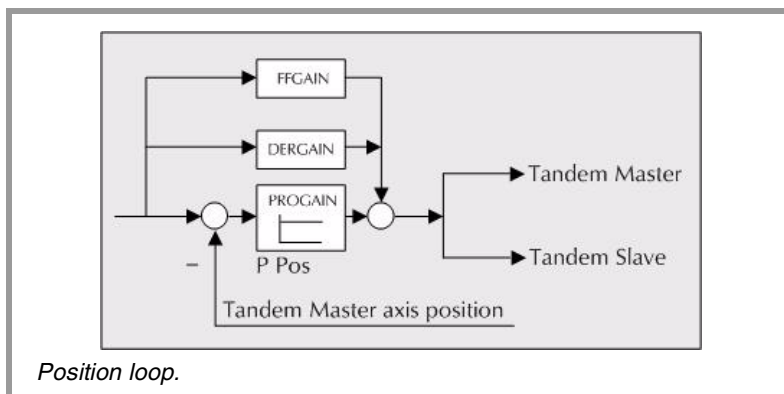

## 4.2 Control of the tandem axis

The block diagram for the application to control the tandem axis is:

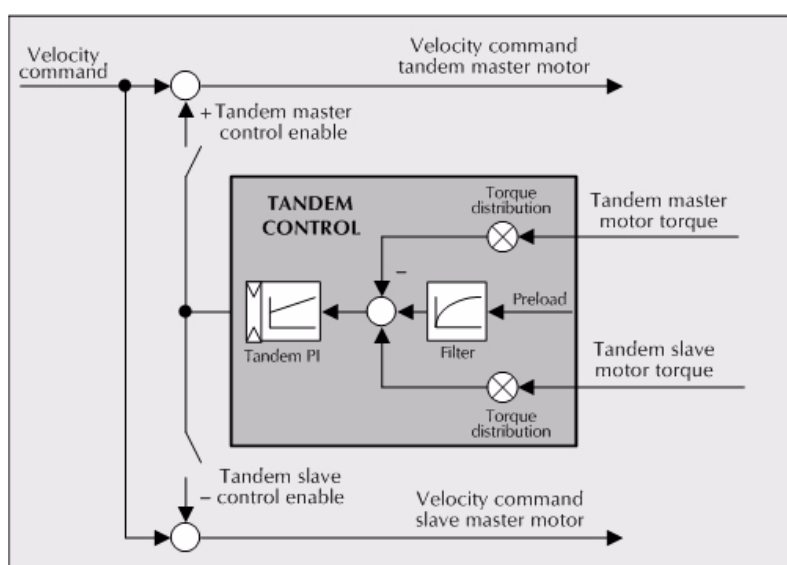

The nomenclature used has the following meaning:

- Torque of the tandem master motor** Is the rated torque percentage (%) reflected by the Sercos variable TV2 of the drive that governs the master axis of the tandem. It is read in every loop.
- Torque of the tandem slave motor** Is the rated torque percentage (%) reflected by the Sercos variable TV2 of the drive that governs the slave axis of the tandem. It is read in every loop.
- Torque distribution** Gain to regularize the torques generated by the motors in order to set a torque distribution other than a 1:1 ratio.
- Pre-load** Previous torque applied to both axes of the tandem in opposite directions. This sets a traction between them in order to eliminate the rack-and-pinion backlash when resting. It is determined as the torque difference provided by each axis.



*Applying the pre-load value involves necessarily joining the master and the slave axes of the tandem axis mechanically. Otherwise, the motors would move even without control command signal.*

- Pre-load filter** First order filter whose purpose is to avoid the input of torque steps (shoulders) when configuring the pre-load.



NEW FEATURES

(SOFT M: 9.0x)

**PI of the tandem**

PI whose function is to guarantee that each motor outputs its corresponding amount of torque. It increases the velocity command if the supplied torque is too low and it decreases it if it is too high.

When defining a tandem axis, the CNC reads through Sercos in each loop the torque supplied by the master and slave axes. This may result in a smaller number of read-write variables in the fast Sercos channel, through PLC parameters.



*This situation may generate a "Sercos ring error", even when using the same variables and number of axes as in a non-tandem configuration. This situation is especially critical for a loop time of 2 milliseconds.*

**Pre-load application in different situations**

**Pre-load in rest mode**

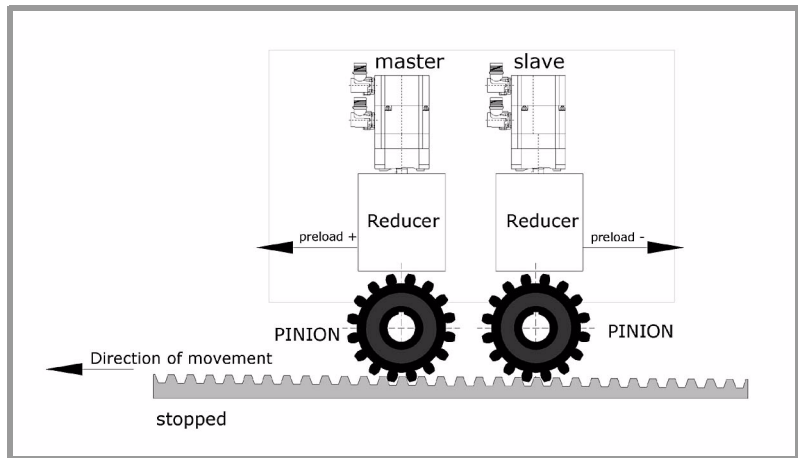

**Pre-load with acceleration**

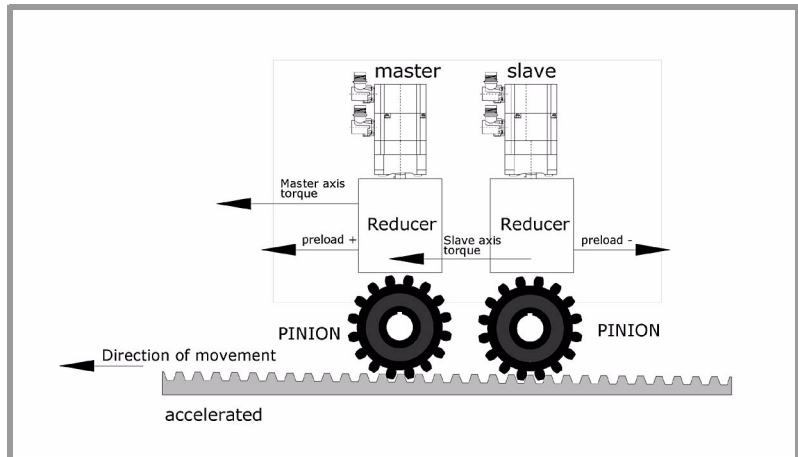

NEW FEATURES

(SOFT M: 9.0x)

**Pre-load at constant speed. Friction torque < pre-load torque**

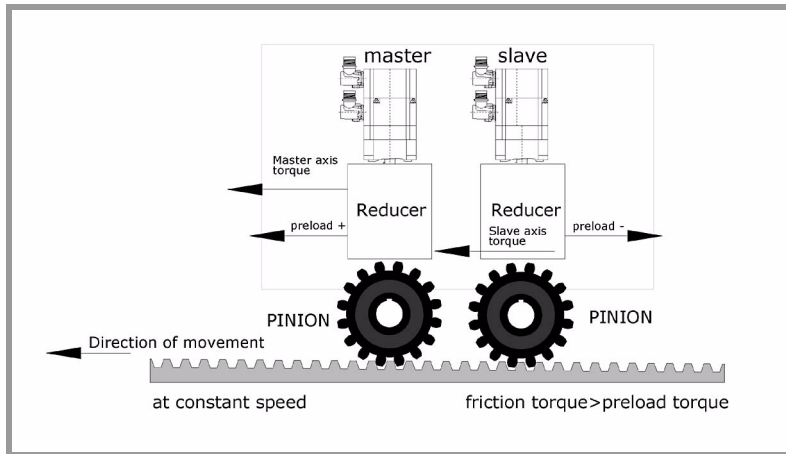

**Pre-load at constant speed. Friction torque > pre-load torque**

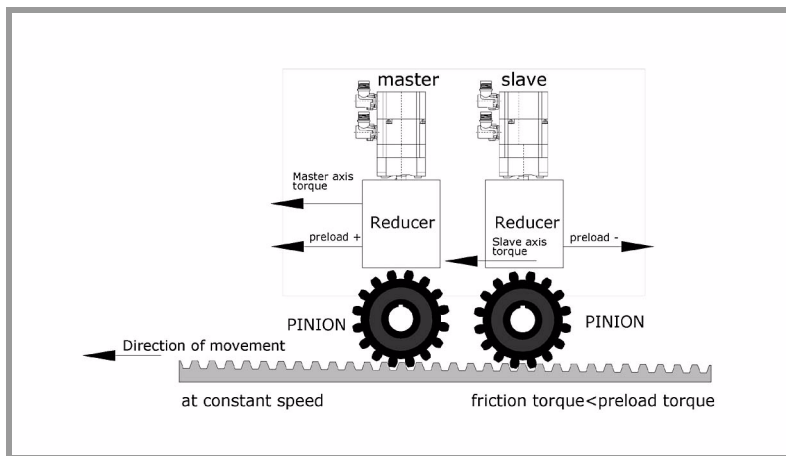

**Pre-load with deceleration**

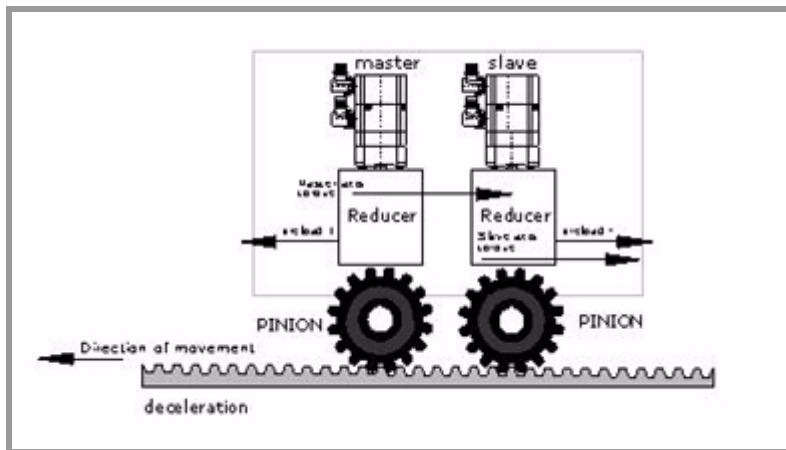

### 4.3 Machine parameter setting

The tandem control is defined with the following axis machine parameters.

These parameters are located in the parameter table of the master axis. The slave axis does not have an axis table at the CNC, although it is possible to access the parameter and variable tables of the slave axis drive. It is accessed from the machine parameters > drive.

#### TANSLAID (P76) TANdem SLAveID

Sercos identifier ID of the tandem slave axis. This parameter of the master axis of the tandem selects the axis that will generate the velocity command for the slave axis.

This parameter enables all the other parameters of the tandem. If this parameter is zero, there is no tandem axis and it ignores the values of the rest of the tandem control parameters.

#### TANSLANA (P77) TANdem SLAve NAme

Slave axis of the tandem.

0 None	1 - X axis	2 - Y axis	3 - Z axis	4 - U axis
5 - V axis	6 - W axis	7 - A axis	8 - B axis	9 - C axis
By default: 0				

This parameter is used in the following cases:

- To identify the marks of the slave axis DRENA\*, SPENA\*, DRSTAF\* and DRSTAS\*. To refer to these marks, it is recommended to use as indexes the letters X-C (e.g. DRENAX, SPENAZ). Numerical indexes (e.g. DRENA1, SPENA2) follow a special criteria; they are the ones following the rest of non-slave axes.
- Identify at the CNC the errors of the tandem slave axis.
- Identify the parameter tables of the tandem slave axis drive.

#### TORQDIST (P78) TORQue DISTribution

Torque distribution. It indicates the torque supplied by each motor in order to obtain the necessary total torque on the tandem axis.

This parameter refers to the master axis. It is defined as the percentage of the total torque demanded from the master axis. The difference between the value of this parameter and the 100% is the percentage that will be applied to the slave axis.

If the motors are identical and they're both supposed to output the same torque, this parameter should be set to 50%.

---

*Possible values:* from 0 to 100%.

*By default:* 50%

---

This parameter can be modified from the oscilloscope and from the PLC.



NEW FEATURES

(SOFT M: 9.0x)



## PRELOAD (P79)

Pre-load between both motors. In other words, the torque difference to be applied between the master and the slave axes. This sets a traction between them in order to eliminate the rack-and-pinion backlash when resting.

This parameter refers to the master axis. It is defined as a percentage of the rated torque to be applied as pre-load.

In order for both axes to output opposite torques, the pre-load value must be greater than the maximum torque needed at all times, including accelerations.

---

*Possible values:* from -100% to 100%.

*By default:* 0 (pre-load is disabled).

---

This parameter can be modified from the oscilloscope and from the PLC.



*Applying the pre-load value involves necessarily joining the master and the slave axes of the tandem axis mechanically. Otherwise, the motors would move even without control command signal.*

## PRELFITI (P80) PRELoad Filter Time

Pre-load filter. It eliminates the torque steps (shoulders) at the input of the tandem compensator when setting a pre-load value. This avoids a step (shoulder or sudden change) in the velocity commands of the master and slave axes of the tandem.

Setting to zero disables the filter.

---

*Possible values:* from 0 to 65535 milliseconds.

*By default:* 1000 ms

---

This parameter can be modified from the oscilloscope and from the PLC.

## TPROGAIN (P81) Tandem PROGAIN

Value of the proportional gain ( $K_p$ ) for the tandem axis. The proportional controller generates an output proportional to the torque error between the two motors.

$$k_p = \left( \frac{S_{\max}}{T_{\text{nom}}} \right) \times \text{TPROGAIN}$$

$$T_{\text{error}} = (-T_{\text{master}} + T_{\text{slave}} + \text{Preload})$$

$$\text{Speed} = k_p \cdot T_{\text{error}}$$

---

*Possible values:* from 0 to 100%.

*By default:* 0 (proportional gain not applied)

---

This parameter can be modified from the oscilloscope and from the PLC.

Example: A tandem axis has a maximum speed of 2000 rpm and a rated torque of 20 Nm. TPROGAIN = 10%.

$$K_p = (2000 \text{ rpm} / 20 \text{ Nm}) \cdot 0.1 = 10 \text{ rpm} / \text{Nm}.$$

**TINTTIME (P82) Tandem INTEGRal TIME**

Integral gain (Ki) for the tandem axis. The integral controller generates an output proportional to the integral of the torque error between the two motors.

$$k_i = \frac{\text{ControlTime}}{\text{IntegralTime}} \times k_p$$

$$T_{\text{error}} = (-T_{\text{master}} + T_{\text{slave}} + \text{Preload})$$

$$\text{Speed} = k_i \cdot \sum T_{\text{error}}$$

---

*Possible values:* from 0 to 65535 milliseconds.

*By default:* 0 (integral gain not applied)

---

This parameter can be modified from the oscilloscope and from the PLC.

**TCOMPLIM (P83) Tandem COMPensation LIMit**

This parameter limits the maximum compensation applied by the tandem axis. This limit is also applied to the integral.

This parameter refers to the master axis. It is defined as percentage of the maximum speed of the master axis.

---

*Possible values:* from 0 to 100%.

*By default:* 0

---

This parameter can be modified from the oscilloscope and from the PLC.

**4.4 Variables****TPIOU(X-C) Tandem PI Output**

Output of the PI of the tandem master slave in rpm.

Variable that may be read from the CNC, PLC and DNC and it may be accessed from the oscilloscope.

**4.5 Tandem adjustment****Adjustment procedure**

In this process, bear in mind the type of machine being used. In general, a tandem machine has a low resonance frequency. Therefore, the CNC must generate position commands without frequency components higher than resonance frequency.

It is recommended to begin the process with low jerk values (lower than 10 m/sec<sup>3</sup>) and low Kv. They can always be increased in later readjustments.

## Steps to follow in the adjustment

### 1. Move both axes independently.

The first step is to ensure the perfect operation of both the master and the slave axis separately. Also check that both axes move in the same direction and with similar dynamics.

To do this, the following methods may be used:

- Define a master axis and a slave axis using a separate parameter table for each axis. When adjusting the master axis, set the slave axis as a dro axis and viceversa.
- Cancel the "drive enable" of the slave axis and move the master axis. Change the parameter settings of the CNC to turn the slave axis into the master axis and repeat the process.

### 2. Move one of the motors at a constant low speed.

- 2.1. Do not make jerky movements because the second motor is being dragged by the first one. In this situation, any acceleration or deceleration that takes place forces it to switch from one side to the other of the backlash without suffering jerks.
- 2.2. Check that the turning directions of both motors are coherent once the movement has been made.



*Note that a reversal of the turning direction of a motor reverses the torque direction and, therefore, it will be necessary to change the sign of its monitored values through drive parameters SP43 and TP85.*

- 2.3. Verify that the gear ratio on both motors is the same (same feedrate for the same turning speed).
- 2.4. Do a basic adjustment of the velocity loop so it lets the machine move. Later on, readjust it with both motors at the same time.
- 2.5. Do not set the friction parameters (enough torque is already supplied to generate movement on the machine).

### 3. Repeat the process with the second motor.

When adjusting the loops, use the same parameters if the motors are identical and the torque distribution is 50%. If the motors are different, the axes must be adjusted so their dynamic response is the same or similar. When using ACForward ("ACFGAIN" = YES), remember that each motor has half the inertia for a torque distribution of 50%.

### 4. Enable the tandem with both motors.

- 4.1. Disable the Pi of the tandem.
- 4.2. Apply power and check that the system is in rest mode.
- 4.3. Enter a low proportional value and eliminate the integral value of the tandem's PI.

- 4.4. Without pre-load, verify that the machine moves and that each motor provides its corresponding torque according to parameter "TORQDIST" (e.g. for a 50% distribution, half the torque).
- 4.5. Monitor the torque of each motor (Sercos variable TV2). When stalled, increase the pre-load gradually until the motors provide torque in the opposite direction.
- 4.6. Slowly move in both directions and check that it works properly. Make sure that it is not jerky and that each motor provides its corresponding torque according to parameters "TORQUEDIST" AND "PRELOAD".
- 4.7. Readjust the velocity loop on both motors with the method normally used.



---

*While changing the parameters of the velocity loop, it would be best to change them on both drives at the same time. Since this is not possible, we recommend to make small changes on the values or change them while the motor is stopped.*

---

## 5 Incline axis management

On certain machines, the axes are not configured as Cartesian, they form angles other than  $90^\circ$  between them, instead. A typical case is the X axis of a lathe that, for sturdiness, it is not at  $90^\circ$  of the Z axis, but at another angle.

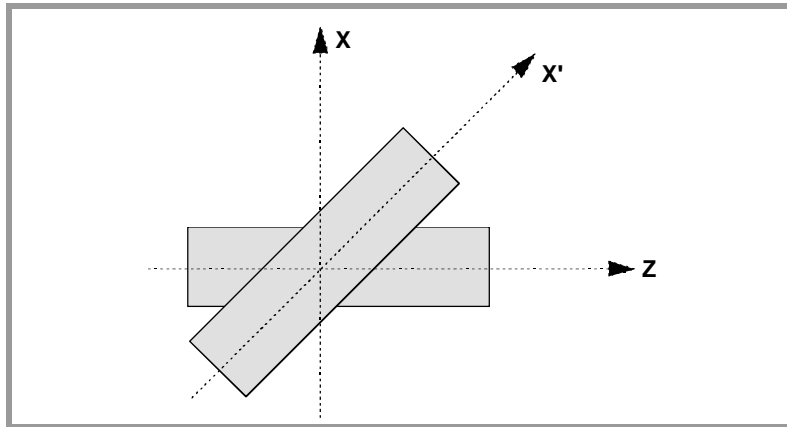

In order to program it in the Cartesian system (Z-X), activate the incline axis transformation to convert the movements to the non-perpendicular real axes (Z-X'). This way, a movement programmed on the X axis is transformed into movements on the Z-X' axes. In other words, it switches to making movements along the Z axis and the angular axis X'.

### Machine parameter setting

The incline axis transformation is defined with the following general machine parameters.

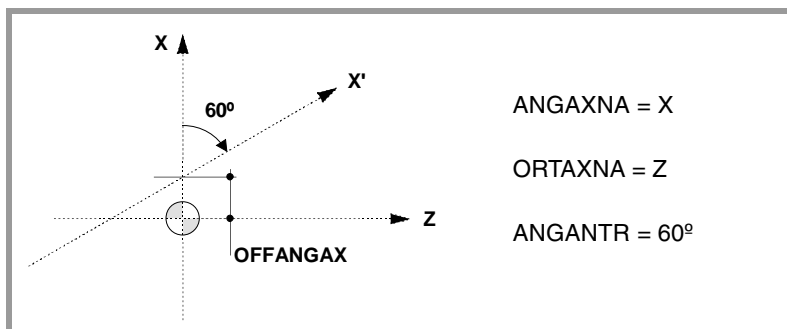

#### ANGAXNA (P171) ANGular AXis NAmE

Incline axis.

0 None	1 - X axis	2 - Y axis	3 - Z axis	4 - U axis
5 - V axis	6 - W axis	7 - A axis	8 - B axis	9 - C axis

By default: 0

#### ORTAXNA (P172) ORTHogonal AXis NAmE

Axis perpendicular to the Cartesian axis associated with the incline plane.

0 None	1 - X axis	2 - Y axis	3 - Z axis	4 - U axis
5 - V axis	6 - W axis	7 - A axis	8 - B axis	9 - C axis

By default: 0

**ANGANTR (P173) ANGLE ANgular TRansformation**

Angle between the Cartesian axis and the incline axis it is associated with.

It is measured in that direction and its units are degrees, between -90° and 90°. Positive angle if clockwise and negative if counterclockwise. If its value is 0°, it requires a transformation.

**OFFANGAX (P174) OFFset ANgular AXis**

Distance between the machine zero point the origin of the coordinate system of the incline axis.

**Programming**

The incline axis transformation may be activated and deactivated with function G46. This function may be programmed as follows:

- G46 S0 or G46  
Cancels incline axis transformation.
- G46 S1 (Standard incline axis transformation)  
The movements are programmed in the Cartesian system. These movements are transformed in movements on the real axes.
- G46 S2 (Special incline axis transformation)  
Special mode to move along the incline axis, but programming the coordinate in the Cartesian system. While this mode is active, in the motion block only the coordinate of the incline axis must be programmed. If the block contains another axis, the movement is carried out according to the normal transformation of the incline axis.

Function G46 is modal and it must be programmed alone in the block. Incline axis transformation stays active after a RESET, M30 and even after turning the CNC off and back on. It is deactivated after a home search.

**Considerations**

The axes defined in parameters "ANGAXNA" and "ORTAXNA" must exist and must be linear. These axes may have associated with them gantry axes, coupled axes or axes synchronized by PLC.

While searching home, the movements are carried out on the incline axes of the machine.

The following operations are possible while incline axis transformation is active:

- Part zero offsets (G54-G59).
- Presets (G92, G93).
- Continuous jog, incremental jog and handwheel movements.

But, the following operations cannot be carried out:

- Tracing (G23)
- Movement up to a hard stop (G52).
- Coordinate rotation (G73).
- Milling surface feedrate (G96).



NEW FEATURES

(SOFT M: 9.0x)

PLC mark "MACHMOVE" determines how the manual movements with handwheels or with the keyboard will be carried out.

- "MACHMOVE"=0. The movements are referred to the Cartesian axes.
- "MACHMOVE"=1. The movements in jog mode with handwheels or with the keyboard are carried out on the incline axes of the machine.

If the transformation is active, the displayed coordinates will be those of the Cartesian system. Otherwise, the coordinates of the real axes will be displayed.



NEW FEATURES

(SOFT M: 9.0x)

## 6 Additive coupling between axes

A typical application of additive coupling is on milling machines where the Z axis has a second axis W coupled to it that moves by hand. This allows operating manually on the Z component through that axis.

This way, the Z axis movements are defined by two axes. One motorized, whose parameters are defined in the Z axis parameters and the other one (dro) whose parameters are defined in the W axis.

The CNC screen shows, in the Z axis coordinates, the sum of both feedbacks Z+W. The coordinates of the W axis may be displayed either as a separate axis or may be set to be hidden (not displayed). Likewise, the graphics show the Z axis as the sum of Z+W.

The additive coupling may be applied on any pair of axes, but only one pair of axes may be defined in an additive coupling. An additive coupling is not possible with the spindle.

### Operation in jog mode

The W axis may be moved manually without affecting the Z axis. The Z axis display shows the sum of both axes.

When moving the Z axis, it moves up to the software limits of the Z axis taking into account the W axis position at the time.

### Operation in the other modes (execution, etc.)

The W axis movements may be compensated on the Z axis via PLC. This is done by adding, in the PLC, the feedback increments of the W axis to the PLCOFZ variable.

The CNC always monitors the software limits of both axes separately. If any of the limits is exceeded, it will issue the corresponding error on the Z or W axis.

It also monitors the software limits of the Z axis when programming a movement either in execution or in JOG mode. In other words, when moving the Z axis in JOG, it moves up to the software limits of the Z axis taking into account the W axis position at the time.

### Home search

To carry out a full home search, do a home search on both axes separately.

- Z axis home search. When detecting the marker pulse, the Z axis display shows the "REVALUE" of the Z axis plus the position of the W axis. The PLCFZ variable is set to zero. The W axis is not involved in the home search.
- Manual W axis home search. When detecting the marker pulse, the W axis display shows the "REVALUE" of the W axis. The Z axis display shows the Z axis position plus the "REVALUE" of the W axis plus W axis position.



NEW FEATURES

(SOFT M: 9.0x)



## 6.1 Configuration

The two axes have separate machine parameters. The additive coupling is configured with the axis machine parameters "SWITCHAX" and "SWINBACK" of the DRO axis.

Likewise, we recommend to set general machine parameter "DIPLCOF=2" so the motorized axis position display shows the PLCOF\* component.

**SWITCHAX (P65)** This DRO axis parameter indicates which is the main axis it is associated with.

0 None	1 - X axis	2 - Y axis	3 - Z axis	4 - U axis
5 - V axis	6 - W axis	7 - A axis	8 - B axis	9 - C axis

By default: 0

**SWINBACK (P66)** This DRO axis parameter indicates that an additive coupling is to be carried out on the axis indicated by parameter "SWITCHAX".

Value	Meaning
10	Additive coupling

## 6.2 PLC program

We recommend to manage the compensation through PLCOFZ with a periodic subroutine whose period is the same as the time set in LOOPTIME.

The SWITCH\* mark is not involved in the additive coupling.

The following example assumes that the Z axis is motorized and that the W axis is a DRO axis. The W axis is coupled with the Z axis.

```

;
; ***** COMPENSATION OF THE W AXIS MOVEMENT WITH PLCOFZ *****
;
;R73 - Operation mode
;R74 - previous POSW
;R75 - current POSW
;R76 - Resulting PLCOFZ
;R77 - previous PLCOFZ
;
CY1                                ; ### FIRST CYCLE ###
() = CNCRD(POSW,R74,M9)
END
;
PRG                                ; ### MAIN PROGRAM ###
REA
() = CNCRD(OPMODA,R73,M9)
NOT B0R73 = JMP L17                ; The W axis is only compensated in execution
() = CNCRD(POSW,R75,M9)
= CNCRD(PLCOFZ,R77,M9)
= SBS R75 R74 R76
= SBS R77 R76 R76
= MOV R75 R74
= CNCWR(R76,PLCOFZ,M9)

```



NEW FEATURES

(SOFT M: 9.0x)

```

= JMP L18
L17
() = CNCRD(POSW,R74,M9)
L18
END

```

## 7 TCP management on rotary table

TCP transformation allows modifying the orientation between the part and the tool without modifying the position of the tool tip. In the case of rotary tables, the rotary axes are located on the work table.

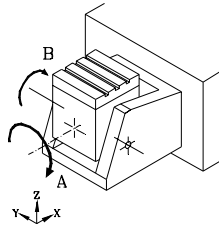

### AB table

The main rotary axis is oriented along the X axis.  
The secondary rotary axis is oriented along the Y axis.

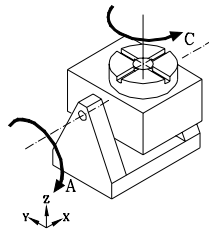

### AC table

The main rotary axis is oriented along the X axis.  
The secondary rotary axis is oriented along the Z axis.

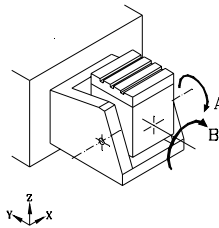

### BA table

The main rotary axis is oriented along the Y axis.  
The secondary rotary axis is oriented along the X axis.

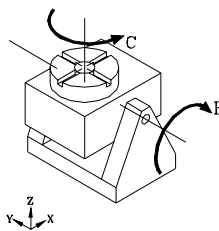

### BC table

The main rotary axis is oriented along the Y axis.  
The secondary rotary axis is oriented along the Z axis.

To define this new kinematics, the machine parameters are set as follows:

**XFORM (P93)** It indicates the type of spindle or table. New value to define rotary tables.

- 0 Standard spindle.
- 1 Reserved.
- 2 Orthogonal, spherical or oscillating spindle.
- 3 Angular spindle.
- 4 Rotary table.



NEW FEATURES

(SOFT M: 9.0x)

**XFORM1 (P94)** It defines the axes of the table and their order (sequence).

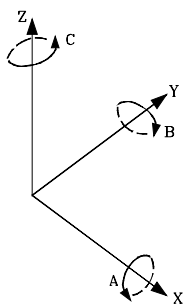

The rotary tables are called A, B, C depending on whether the rotating axis coincides with the X, Y and Z axes respectively. The turning direction of the axes may be changed with parameter "XFORM2".

When having a rotary axis "XFORM=4", parameter "XFORM1" indicates which is the main axis and which one is the secondary or "dragged" axis.

- XFORM1=0 A is the main axis and B is the secondary axis.
- XFORM1=1 A is the main axis and C is the secondary axis.
- XFORM1=2 B is the main axis and A is the secondary axis.
- XFORM1=3 B is the main axis and C is the secondary axis.

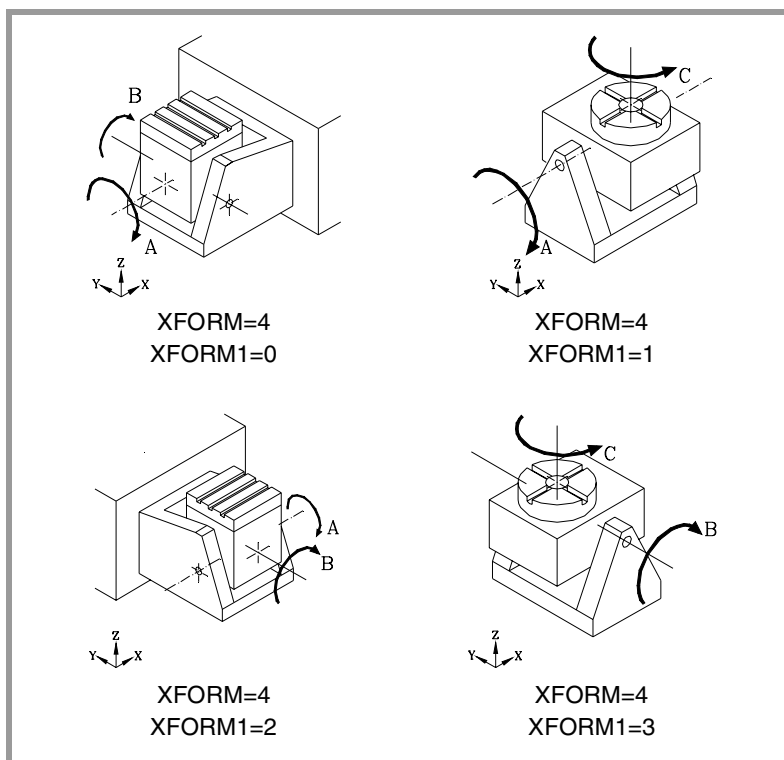

**XFORM2 (P95)** It defines the turning direction of the rotary axes.

- 0 The one indicated by the DIN 66217 standard.
- 1 It changes the turning direction of the main axis.
- 2 It changes the turning direction of the secondary axis.
- 3 It changes the turning direction of both axes (main and secondary).

**XDATA0 (P96)** Not being used.

**XDATA1 (P97)** Not being used.

**XDATA2 (P98)** Position of the secondary rotary axis or of the intersection between the primary and secondary axes along the X axis, referred to machine zero.

**XDATA3 (P99)** Position of the secondary rotary axis or of the intersection between the primary and secondary axes along the Y axis, referred to machine zero.

**XDATA4 (P100)** Position of the secondary rotary axis or of the intersection between the primary and secondary axes along the Z axis, referred to machine zero.

**XDATA5 (P101)** Distance from the secondary rotary axis to the main rotary axis.

**XDATA6 (P102)** Not being used.

**XDATA7 (P103)** Not being used.

**XDATA8 (P104)** Not being used.

**XDATA9 (P105)** Not being used.

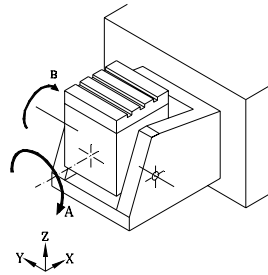

XFORM=4  
XFORM1=0

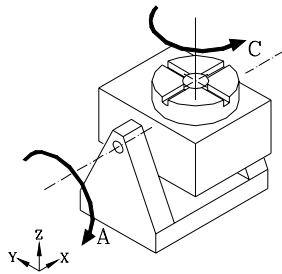
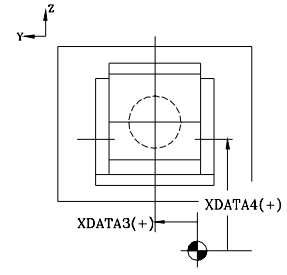
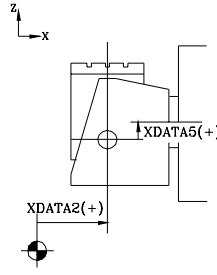

XFORM=4  
XFORM1=1

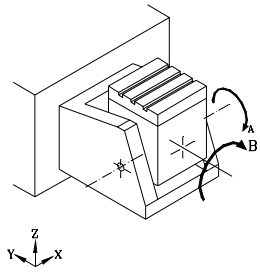
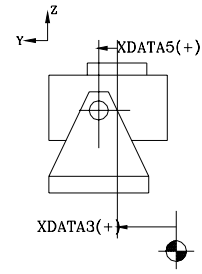
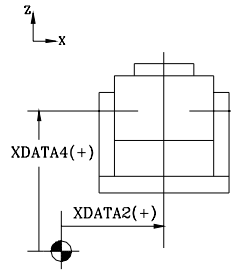

XFORM=4  
XFORM1=2

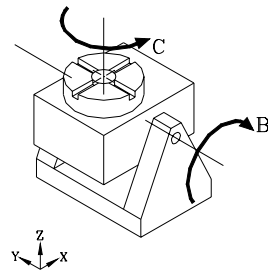
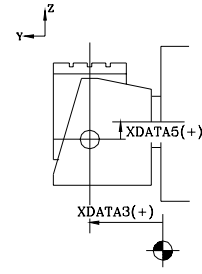
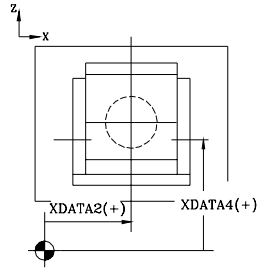

XFORM=4  
XFORM1=3

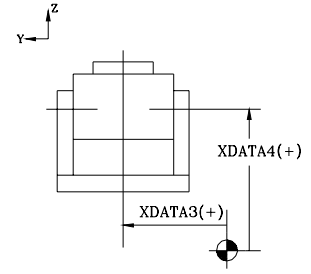
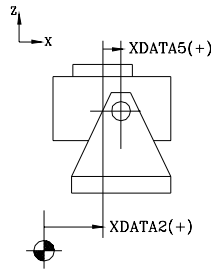

NEW FEATURES

(SOFT M: 9.0x)

## 8 Tool change

### 8.1 Stop block preparation when executing a new T

When having a subroutine associated with the "T" function, the tool change is carried out as follows:

1. It executes the associated subroutine.
2. It executes the "T" function. Function M06 is not used.
3. The CNC assumes the change.

Block preparation is not interrupted during the tool change. If a programming error is detected during block preparation, the execution of the "T" function might not be completed. This means that the tool change may have concluded correctly but the requested tool has not been assumed by the CNC.

To avoid this situation, it is possible to stop block preparation during the execution of the "T" function. bit 1 of g.m.p. "TOOLTYPE" determines whether to interrupt block preparation or not.

- 0 Block preparation is not interrupted.
- 1 Block preparation is interrupted.

**TOOLTYPE (P167)** This parameter has 16 bits counted from left to right. Each bit has a function or work mode associated with it. By default, all bits are set to "0". Setting a bit to "1" activates the corresponding function.

Bit	Meaning
1	Stop block preparation when executing a new "T".
2	Round corner when changing the tool offset.
3	The STOP signal is always executed after the "T" function.
4-16	<i>Not being used.</i>

### 8.2 New treatment of CYCLE STOP during the execution of a T

When the tool change subroutine has been defined so it is executed as a single block and the stop signal has been disabled, the following occurs: When pressing [CYCLE STOP] while the subroutine is being executed, the CNC stores it and it stops right when the stop signal is enabled. In this situation, it does not finish the subroutine and it does not consider the T as done, which could cause irregularities at the tool magazine.

From this version on, a new behavior may be defined. The stop signal is always executed after the T has been fully executed regardless of whether the stop signal has been disabled or not in the subroutine.

It should be borne in mind that the DSTOP instruction disables both the [CYCLE STOP] key and the signal coming from the PLC. Both may be re-enabled with the ESTOP instruction.

Bit 3 of g.m.p. "TOOLTYPE" determines when not to ignore the stop signal.

- 0 When there is a subroutine associated with the "T" function, the stop signal is considered (not ignored) in the following cases.
  - If the stop signal has been disabled, when it is re-enabled.
  - If the stop signal has not been disabled, when pressing the [CYCLE STOP] key.
- 1 The stop is always executed after the execution of the T.



NEW FEATURES

(SOFT M: 9.0x)

**TOOLTYPE (P167)** This parameter has 16 bits counted from left to right. Each bit has a function or work mode associated with it. By default, all bits are set to "0". Setting a bit to "1" activates the corresponding function.

Bit	Meaning
1	Stop block preparation when executing a new "T".
2	Round corner when changing the tool offset.
3	The STOP signal is always executed after the "T" function.
4-16	<i>Not being used.</i>

## 9 Modification of the operation of the feedrate when it is F0

**FEEDTYPE (P169)** It defines the behavior of the feedrate when programming F0.

- 0 Movement at maximum feedrate allowed.
- 1 F0 cannot be programmed.

FEEDTYPE=0.

F0 can be programmed. When there are motion blocks, they are executed at the maximum feedrate allowed.

FEEDTYPE=1.

F0 cannot be programmed. When trying to program F0, it shows error 246 "Negative or 0 feedrate cannot be programmed". When trying to execute a motion block while the active F is "0", it displays the error 1073 "Motion block with zero feedrate".

## 10 The cross compensation on gantry axes affects the slave axis

**TYPXCROSS (P135)** From this version on, this g.m.p. has two digits.

The units indicate whether cross compensation is applied with theoretical coordinates or with real ones.

- x0 With real coordinates. (Default value)
- x1 With theoretical coordinates.

The tens indicate whether cross compensation affects only the master axis or both.

- 0x It affects the master axis. (Default value)
- 1x It affects the master and the slave axes.

Bear in mind that the cross compensation tables only refer to the master axis. The slave axis is compensated with the values set for the master axis.



NEW FEATURES

(SOFT M: 9.0x)

## 11 Subroutines associated with M41, M42, M43, M44

With the s.m.p. "AUTOGEAR" = YES, when programming an S, the gear change is carried out automatically. The CNC generates internally an auxiliary function (M41, M42, M43 or M44) depending on the programmed S value. In this case, functions M41 through M44 could not have an associated subroutine and it would issue error 1031 "subroutine not allowed with automatic gear change".

From this version on, functions M41 through M44 may be defined with an associated subroutine. The S that generates the gear change must be programmed alone in the block; otherwise, it will issue the error 1031 mentioned earlier.

If an M41-M44 has been programmed before and an S is programmed that corresponds to the gear for that M, it does not generate an automatic gear change and, therefore, it will not execute any subroutine.

## 12 Probe input selection

When having two probe inputs, the active probe input may be selected with the "SELPRO" variable.

**SELPRO** It may be used to select the active probe input.

On power-up, it assumes the value of "1" thus selecting the first probe input. To select the second probe input, set it to a value of "2".

---

SELPRO = 1 It selects the first probe input.

SELPRO = 2 It selects the first probe input.

---

The "SELPRO" variable can be read and written from the CNC and the PLC and read from the DNC. Accessing this variable from the CNC interrupts block preparation.

## 13 Programming in radius or diameter

Programming in radius or diameter may be selected via program using the "DIAM" variable.

**DIAM** It may be used to change the programming mode for X axis coordinates between radius and diameter.

DIAM=0 The programmed coordinates are assumed in radius.

DIAM=1 The programmed coordinates are assumed in diameter.

When changing this variable, the CNC assumes the corresponding programming mode for the blocks programmed next. It also affects the display of the real value of the X axis in the coordinate system referred to the part. When reading variables PPOSX, TPOSX and POSX.

This variable can be read and written from the CNC and the PLC, but only read from the DNC.



NEW FEATURES

(SOFT M: 9.0x)

On power-up, after executing an M02 or M30 and after an emergency or a reset, the variable is initialized according to the value of the DFORMAT parameter of the X axis. If this axis has a value equal to or greater than 4, the variable takes a value of 1; otherwise, it takes the value of 0.

## 14 Program G2 and G3 without the center coordinates (I, J, K)

When programming an arc (G02/G03), the coordinates of the center may be left out when their value is zero.

If when executing or simulating the arc, the center coordinates (I, J, K) have not been defined, it takes them as zero and it tries to make an arc with that center. If the arc cannot be made, it will issue the corresponding error message.

## 15 Changing the kinematics by program

Changing the kinematics requires modifying the general machine parameters associated with them and validating them. From this version on, this may be done from an OEM program.

The machine parameters may be modified and validated from the OEM subroutines. That is why an OEM program may define the different subroutines that will set the machine parameters for each kinematics. Then, the spindle change subroutine will call the subroutine with the spindle parameters to be activated and, then, will call the new INIPAR instruction.

**INIPAR** Instruction to validate the machine parameters modified from the OEM subroutine that defines the kinematics. This instruction is only valid when used in subroutines that are located inside OEM programs.

To validate the machine parameters, G48 and G49 must NOT be active. Otherwise, it shows error 1074 "INIPAR cannot be executed".

## 16 Modifications in PLC operation

### 16.1 Initializing the PLC outputs while compiling the program

From this version on, all the outputs will be initialized to zero during the compilation of the PLC program.

In previous versions, the compilation of the PLC program only initialized to zero the emergency output. The rest remained in the state they had before stopping the interruption of the PLC program.



NEW FEATURES

(SOFT M: 9.0x)



## 16.2 Ending the execution of a block using a PLC mark

The following PLC marks are now defined. They only affect the execution in automatic mode and the simulation with motion:

- |          |   |
|----------|---|
| BLOABOR  | It interrupts the main execution channel. |
| BLOABORP | It interrupts the PLC channel.            |

When detecting one of these marks, it ends the current movement and it starts executing the next block. If the interrupted block had M functions to be executed after the block, they will be executed before going on to the next block.

The marks do not stay active after the execution. Once executed, the CNC deactivates them. Likewise, if they are activated in a block that does not accept them, they will also be deactivated. They are not maintained for the next block.

### ▣ These marks affect the following functions.

- It affect motion blocks G0, G1, G2, G3.
- They affect the dwell programmed with G4.
- It affects the look-ahead. In this type of programs with very small blocks, it is not possible to stop at the same block where the "BLOABOR" mark is detected. In these cases, it will be canceled at the block where the axis is fully decelerated.

### ▣ These marks do not affect the following functions.

- It does not affect motionless blocs, which will be executed.
- It does not affect the M functions that are executed after the block. These functions are always executed, even if the movement of the block is interrupted.
- It does affect not affect threading blocks G33. It does not affect the tapping or rigid tapping cycles either, regardless of whether g.m.p. "STOPTAP" is set to NO or to YES.
- It does not affect spindle positioning blocks M19 S\*. If the spindle positioning is in a block containing axis movement, it aborts the movement of the axes, but it completes the positioning of the spindle.
- It does not affect tracing.
- It has no effect when tangential control is active.

### Considerations for the execution

These marks do not affect block preparation. When canceling the execution of a block, the next movement is carried out up to the target coordinates of that block. It does not resume block preparation.

On the other hand, only the programmed axes are involved in the next movement. The rest of the axes are ignored, even if there is a real difference in position because the previous block has been aborted.

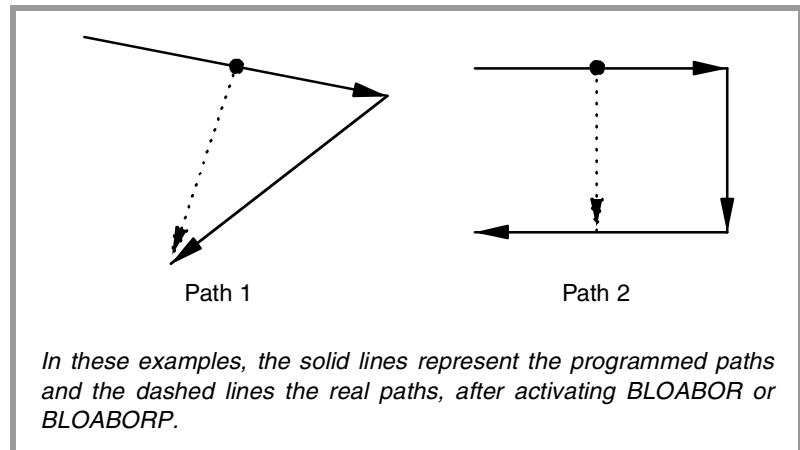

If a block is aborted when there is possibility to retrace and then the RETRACE function is activated, the retraced path (backwards) will not be the same as the one traveled forward. The two paths will not be the same either if a block is aborted while retracing (going backwards).

### 16.3 "Rapid" key controlled by PLC in execution and simulation

From this version on, g.m.p. "RAPIDEN" may be defined with a value of "2". This parameter indicates whether the "rapid" key affects the execution and the simulation or not.

From the PLC, the behavior of this key is managed using the "EXRAPID" mark. When this mark is set high, the operation is as follows:

- "RAPIDEN"=0. The movements are always carried out at the programmed feedrate. The "rapid" key has no effect. The "EXRAPID" mark is ignored.
- "RAPIDEN" = 1. When the mark is activated, the programmed movements are executed in rapid. There is no need to press the key.
- "RAPIDEN" = 2. When the mark is activated, the "rapid" key is enabled. Press the key to make moves in rapid. In other words, both the "rapid" key and the "EXRAPID" key must be active.

## 16.4 Name the logic inputs and outputs with the axis name

New marks are defined for the logic inputs and outputs of the axes. Until now, the marks referred to the logic number of the axis. This meant that when removing an axis, the PLC was not coherent with the axes. From this version on, the marks may be named by referring to the axis name.

- Example of logic inputs for the X axis. The rest of the axes have their equivalent marks.

LIMIT+X	LIMIT-X	DECELX
INHIBITX	MIRRORX	SWITCHX
DROX	SERVOXON	AXIS+X
AXIS-X	SPENAX	DRENAX
SYNCHROX	ELIMINAX	SMOTOFX
LIMXOFF		

- Example of logic outputs for the X axis. The rest of the axes have their equivalent marks.

ENABLEX	DIRX	REFPOINX
DRSTAFX	DRSTASX	ANTX
INPOS1		

The marks of the axes that do not exist in the machine parameters assume the value of the M2045 mark, that's always set to 0.

When monitoring the PLC program, it shows the edited marks, either with a letter or with a number. However, the resource windows created from monitoring will replace the marks with axis names by the marks with axis numbers. For example:

SERVOXON by SERVO1ON

SERVOZON by SERVO2ON if there is no Y axis, but there are X and Z axes.



*If a PLC program older than this version, has defined these marks as symbols, when compiling the program will issue an error on this line.*

*Example: DEF ENABLEX M333*

## 17 New marks to park spindles

There are now new marks ELIMIS, ELIMIS2 and ELIMIAS to park the main, secondary and auxiliary spindle.

The procedure to park a spindle is the same as for the axes, be it Sercos or analog. Once parked, it will not issue feedback alarms.

When the spindle is controlled via Sercos and the PLC sets the corresponding signal high, the commands to park the spindle are generated automatically via Sercos.



NEW FEATURES

(SOFT M: 9.0x)

## 18 Modifications and new variables

**HARCON** It indicates, with bits, the CNC's hardware configuration. The bit will be "1" when the relevant configuration is available.

8055 CNC model:

Bit	Hardware
29	Hard disk integrated into the CPU.
30	Ethernet integrated into the CPU.
31	Compact flash.

8055i CNC model:

Bit	Hardware
30	Ethernet.
31	Compact flash.

**HDMEGA** Hard disk size in megabytes.

**MEMTST** HD test result. Bit 8 will be set to "1" if the test is OK and it will have another value if there is an error.

**HARSWB** It returns, in 4 bits, the central unit configuration.

Bit	
19,18,17,16	Type of CAN present at COM1.
23,22,21,20	Type of CAN present at COM2.

- If the value of the bits is 0001, it will be an SJ1000 type.
- If the value of the bits is 0010, it will be an OKI9225 type.

**IONODE** It may be used to read the position of the "ADDRESS" switch of the CAN of the I/O. If it is not connected, it returns the value 0xFFFF.

Bit	
0-15	CAN of the I/O.

**IOSLOC** They may be used to read the number of digital I/O available.

**IOSREM**

IOSLOC	Number of local I/O.
IOSREM	Number of remote I/O.

Bit	
0-15	Number of inputs.
16-31	Number of outputs.

## 19 Parameters accessible from the oscilloscope or OEM subroutine

The following parameters may be modified from the oscilloscope or OEM program.

### General machine parameters.

Number	Parameter	Update
P147	CODISET	Immediate

### Axis machine parameter.

Number	Parameter	Update
P21	MAXFLWE1	Immediate
P22	MAXFLWE2	Immediate

## 20 MC model. ISO programming assistance

New levels have been added to the current ISO cycle of the conversational mode to be able to program certain preparatory functions easily. The new levels are:

- Zero offsets and presets.
- Work zones.
- Place labels and repetitions from label to label.
- Mirror image.
- Scaling factor.
- Coordinate rotation.

Going from one level to another is done with these keys: [LEVEL CYCLE], [PGUP] and [PGDN].

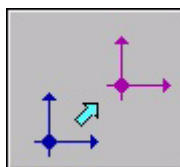

Zero offsets and presets

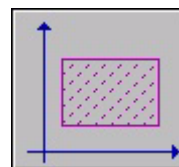

Work zones

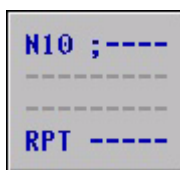

Place labels and repetitions from label to label

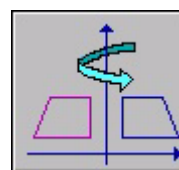

Mirror image

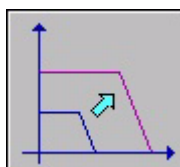

Scaling factor

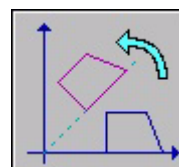

Coordinate rotation

## 20.1 Zero offsets and presets

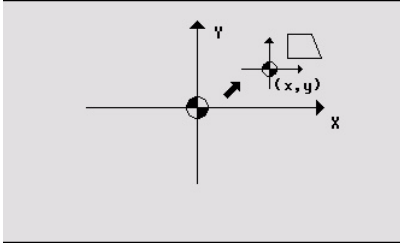

The icon may be used to select the following options:

- Machine zero. It cancels any zero offset and assumes the machine zero (home) as reference.
- Absolute zero offset. It permits defining, enabling or defining + enabling the absolute zero offsets (G54 to G57).  
The zero offset is selected with an icon.
- Incremental offset: It permits defining, enabling or defining + enabling the incremental zero offsets (G58 or G59). The zero offset to be activated is selected with an icon.
- Preset: The preset value for the active axes may be edited on the screen. If any of them is not to be preset, leave its field empty.

The cycle internally generates a block with function G53, G54...G59 or G92.

Pressing the [ZERO] key accesses the zero offset table.

## 20.2 Work zones

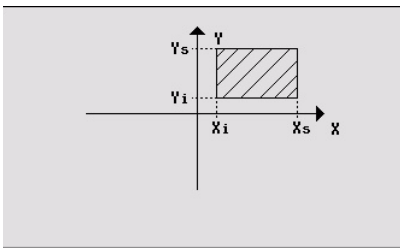

The icons may be used to defined the following options:

- Select the work zone to act upon. Up to five different zones may be defined.
- Type of action to carry out with the zone. A zone may be defined, enabled, defined+enabled or disabled.
- Define the type of zone. Each one of them may be defined either as a no-entry or no-exit zone.

The numeric fields permit editing the lower and upper limits of the zone. The limits are defined on the X, Y, Z axes. To only define either the upper or the lower limit, leave the values of the other limit blank.

The cycle internally generates up to three blocks with functions G20, G21 and G22.

## 20.3 Place labels and repetitions from label to label

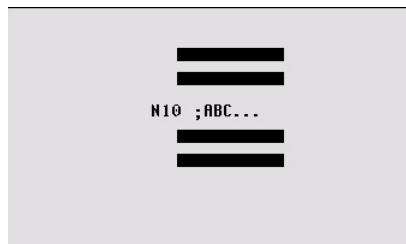

This cycle permits editing labels and repetition blocks between two labels. It is selected with an icon.

- Edit labels. There is a field to enter the block number and another one to add a comment.

The cycle generates this type of a block: N10; -> Comment

- Block repetition. The repetition takes place between the first and final labels programmed, the number of times that is indicated.

The cycle internally generates an RPT block.

## 20.4 Mirror image

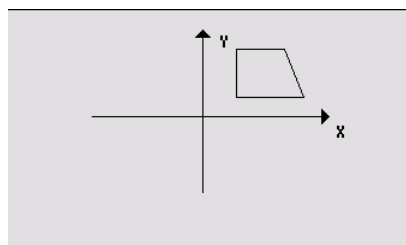

The icons may be used to select the following options:

- Select the action to be carried out. It is possible to cancel the active mirror image, define a new one canceling the previous ones or define a new one and add it to the one that is currently active.
- Select the axes upon which mirror image is applied. For a new mirror image, it is possible to choose from the X, Y or X-Y axes. For an additive mirror image, it is possible to choose between the X and Y axes. This icon is not displayed when selecting to cancel the mirror image.

The cycle internally generates an ISO block that contains a combination of functions G10, G11 and G12.

## 20.5 Scaling factor

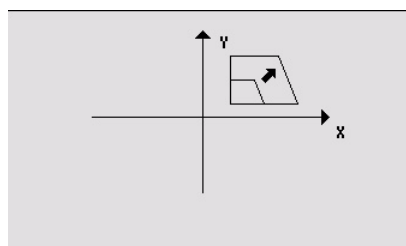

An icon is used to indicate whether to cancel the existing scaling factor or activate a new one. In the latter case, a numeric field is displayed to define the value of the scaling factor.

The cycle internally generates a block with function G72.

## 20.6 Coordinate rotation

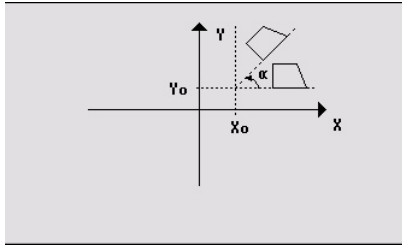

An icon is used to select the action to be carried out. It is possible to cancel the active coordinate rotation, define a new one canceling the previous one or define a new one adding it to the one currently active.

To define or activate a coordinate rotation, it shows three numeric fields to edit the angle and the center of rotation.

The cycle internally generates two blocks with function G73.

## 21 MC model. Zero offset table management

It is possible to manage the zero offset table (G54-G59) from the conversational mode. The table contains the same values as that of the conversational mode.

Accessing the table displays the following screen: The upper right hand area shows the current position of the axes and machining conditions. The table shows all the offsets and their value in each axis.

Scrolling the focus through the table, the elements appear in different colors as follows:

- White text over green background. The real value of the table and the value shown on the screen are the same.
- White text over a red background. The real value of the table and the value shown on the screen are NOT the same. The value on the table has been changed, but it has not been validated. Press [ENTER] to validate the change.
- Blue background. The zero offset is active. There may be two active zeros at the same time, one absolute (G54-G57) and another one incremental (G58-G59).

	X	Y	Z	V
PLC	0.0000	0.0000	0.0000	0.0000
G54	0.0000	0.0000	0.0000	0.0000
G55	0.0000	0.0000	0.0000	0.0000
G56	0.0000	0.0000	0.0000	0.0000
G57	0.0000	0.0000	0.0000	0.0000
ΔG58	0.0000	0.0000	0.0000	0.0000
ΔG59	0.0000	0.0000	0.0000	0.0000



NEW FEATURES

(SOFT M: 9.0x)



### Accessing the offset table

Press the [ZERO] key to access the zero offset table as well as to get out of it.

- From the standard screen, as long as no axis is selected. In this case, it will request confirmation to access the table.
- From the ISO cycle when the cycle for zero offsets and presets has been selected, within the ISO programming assistance.

### Editing and validating the table data

Press [ENTER] to validate the changes. The following operations are possible in the table:

- Load the active zero offset.



Place the focus on the zero offset to be defined (G54-G59) and press the [RECALL] key. The active preset is saved in the selected zero offset.

If instead of placing the focus on a zero offset, it is placed on one of the axes, only that axis will be affected.

- Deleting a zero offset.  
Place the focus on the zero offset to be delete (G54-G59) and press the [CLEAR] key. All the axes of that zero offset are reset to zero. If instead of placing the focus on a zero offset, it is placed on one of the axes, only that axis will be affected.
- Editing a zero offset.  
It is edited one axis at a time. Select a data with the focus and edit its value. If the focus is placed on a zero offset (G54-G59), the editing begins on the first axis of that zero offset.

## 22 MC model. Accessing cycles and programs from the auxiliary screen

From this version on, it is possible to access from the auxiliary window to the various cycles, listing of programs and also remove the program selected for execution (using [CLEAR]).

Bit 15 of g.m.p. "CODISET" determines whether this access is allowed or not.

- 0 Access allowed.
- 1 Access denied.

**CODISET (P147)** This parameter has 16 bits counted from left to right. Each bit has a function or work mode associated with it. By default, all bits are set to "0". Setting a bit to "1" activates the corresponding function.

Bit	Meaning
14	The CNC is configured as having two and a half axes.
15	It is not possible to access cycles and programs from the auxiliary screen.
16	There are auxiliary M functions

## 23 MC model. In case of error in a cycle, point to the erroneous cycle.

If an error occurs in a cycle during simulation or execution, when accessing the list of programs again, the cursor will be placed on the cycle that came up with the error.

When program 999998 is displayed on the screen or the error is not an execution error, the cursor will go to the beginning or to the end of the program depending on its length.

## 24 MC model. Display name and number of the cycle

During the simulation or execution of a program or cycle, it displays the cycle number next to its name. However, when detecting an RPT or GOTO instruction, the cycle number will disappear.



NEW FEATURES

(SOFT M: 9.0x)

## 25 MC model. Highlighting the axis being moved in jog or with handwheels

When making a move in manual, either in jog or with handwheels, the moving axis appears in reverse video.

With gantry axes, only the master axis is highlighted.

With a path handwheel, no axis is highlighted. However, it is highlighted in movements in path jog.

## 26 MC model. Copying a profile

Following these steps to copy a profile:

1. Expand the list of profiles. To do this, place the focus on that element and press [↓].
2. Place the cursor on the profile to be copied and press [PPROG].
3. The CNC requests the number of the new profile and it also allows changing its comment. If the number entered is the same as that of an existing profile, it requests confirmation to replace it.

To exit the list, simply press [←], [→], [ESC], [SHIFT]+[ESC] or any cycle entering key.

## 27 MC model. Select a program by indicating its number

When having lots of programs in memory, it may be cumbersome to select a program with the cursor. It is now possible to select the program by typing its number directly. Before that, the cursor must be on the program listing.

If the desired program does not exist, the cursor will go to the nearest previous one.

For example: To find program number 123, press the keystroke sequence [1], [2] and [3]. The time interval between keystrokes must be shorter than 1.5 seconds. If it takes longer, it will be necessary to start a new sequence.

## 28 MC model. Selection of the reference point in rectangular pockets and bosses.

In the simple rectangular pocket and in the rectangular boss, it may be selected if the reference point is referred to the corner or to the center. When associating multiple machining to a cycle, this point indicates the position where those machining operations are applied.

It is selected with an icon.

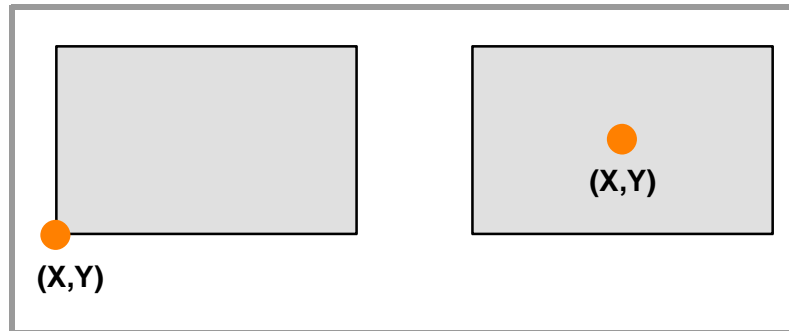

## 29 MC model. Multiple machining in pockets and bosses

Any positioning cycle may be assigned to all the pockets and bosses.

- Simple rectangular, circular and pre-empted circular pocket.
- Rectangular and circular boss
- 2D profile pocket. Pocket with island based on a profile in the XY plane.
- 3D profile pocket. Pocket with islands with a profile in the XY plane and up to 4 profiles with different depths.

The positioning types available are:

- Point-to-point positioning.
- Linear positioning.
- Arc positioning.
- Grid pattern positioning.
- Rectangular pattern positioning.

Pockets and bosses are associated with positioning in the same way as the rest of the cycles (drilling, reaming, etc.).

1. Definition of the machining cycle, including the position of the starting point.
2. Selection of the type of positioning to be associated with.
3. Programming of the different points of the positioning.

The cycle assumes as first positioning point the starting point of the machining operation. This point may be modified when defining the positioning.

In 2D and 3D pockets, the reference points for the positioning must be the starting point of the outside profile.

The screens of the pockets and bosses will indicate with icons which positioning they have associated or whether they are alone.

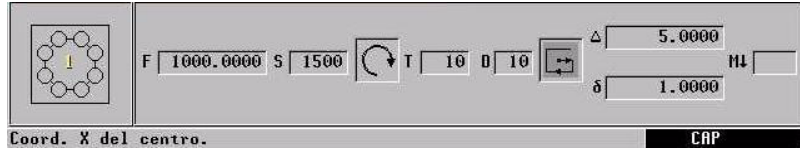

In the positioning, an icon will show the pocket or boss to be repeated and the bottom screen will give information on its geometry (except in profile pockets).

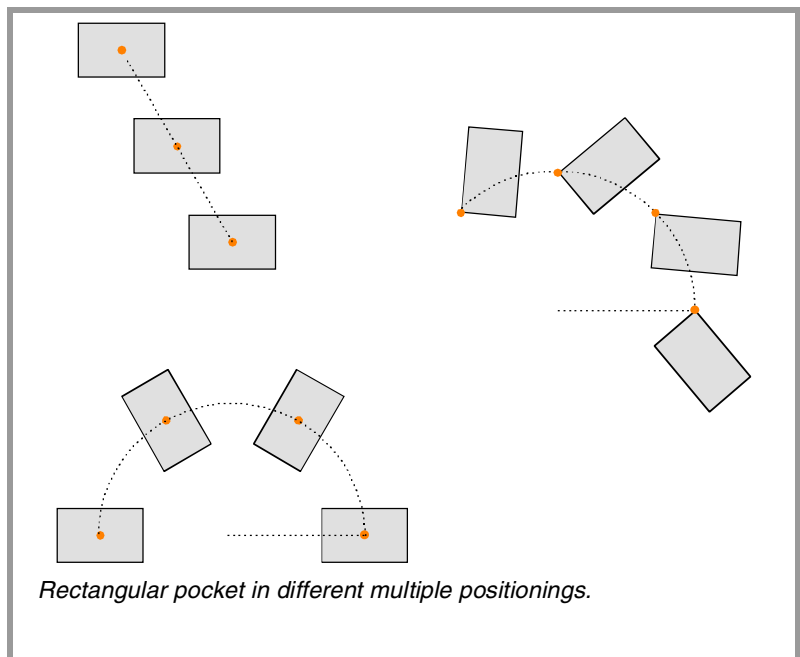
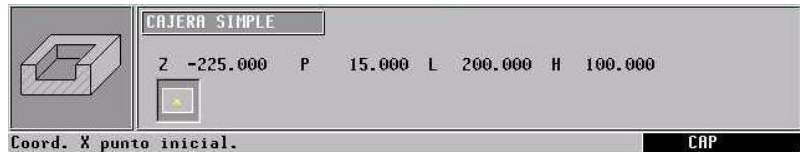

When machining multiple pockets and bosses, proceed as follows:

- There is neither roughing or finishing operation.  
It goes point to point carrying out the cycles at once (there is no tool change).
- There is a roughing and finishing operation with the same tool and it is not possible to program "M" functions between them.  
It goes point to point carrying out the cycles at once (there is no tool change).
- There is a roughing and finishing operation with a different tool or it is possible to program "M" functions between them.  
It first does the roughing and then all the finishing operations (only one tool change).



*The availability of "M" functions in the cycles is determined with g.m.p. "CODISET (P147)".*

## 30 MC model. Configuration of two and half axes

A two-and-a-half-axis configuration is a milling machine where the X and Y axes are motorized and the Z axis is set as a DRO axis (display only). In this configuration, the Z axis is moved manually.

The CNC cycles and interface have been adapted for this type of configuration.

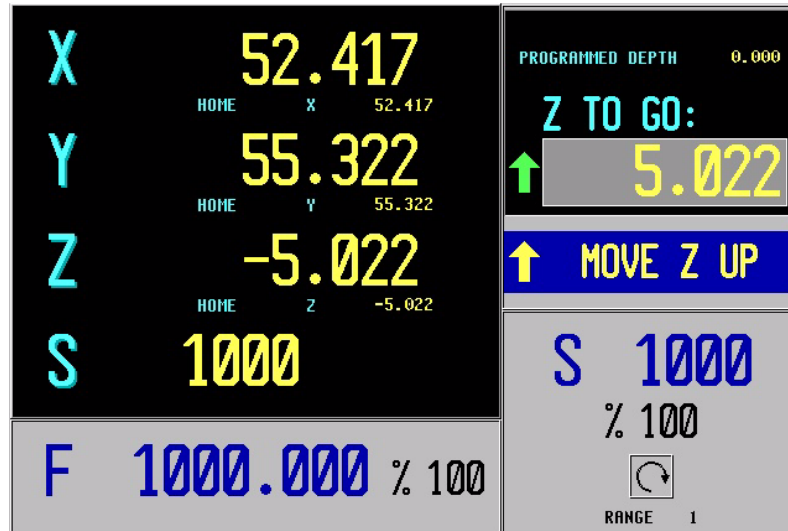

### Editing and execution

The cycles are edited, stored and simulated just like a 3-axis configuration.

The most significant difference lies in the execution because the operator must move the Z axis by hand. The standard screen shows the operations to be carried out by the operator. In each case, it shows the status of the Z axis and the various actions to be executed by the operator.

- Move Z up (it shows an icon next to the final Z coordinate).  
The operator must move the axis up manually. When the Z axis is in position, the message will change.
- Move Z down (it shows an icon next to the final Z coordinate).  
The operator must move the axis down manually. When the Z axis is in position, the message will change.
- Press CYCLE START.  
The operator must press [CYCLE START] to begin the X-Y movement in automatic.
- Moving in X-Y.  
The machine is moving in X-Y. When a Z axis move is required, the machine will stop and it will request the operator's intervention.
- Tool inspection.  
It went into tool inspection.

**Canned cycles**

Not all the cycles can be applied to a two-and-a-half-axis configuration. The following cycles are permitted:

- Positioning 1 and 2.
- Profile milling and profile 1 milling.
- Surface milling.
- Slot milling
- 2D profile pocket.
- Rectangular and circular boss.
- Simple, rectangular and circular pocket 1 and 2.
- Center punching.
- Drilling 1.
- Reaming.
- Boring 1 and 2.
- Multiple positioning, point to point, linear, in arc 1 and 2, in grid and rectangular patterns.

In some of these cycles, some data has been eliminated to adapt them to the two-and-a-half-axis configuration. This data referred to operations of the Z axis.

**30.1 Configuration**

The following machine parameters must be modified to configure the CNC as having two and a half axes:

**CODISET (P147)** Bit 14 determines whether the CNC is configured as having two and a half axes or not. To assume this change, press [RESET].

This parameter has 16 bits counted from left to right. Each bit has a function or work mode associated with it. By default, all bits are set to "0". Setting a bit to "1" activates the corresponding function.

Bit	Meaning
14	The CNC is configured as having two and a half axes.
15	It is not possible to access cycles and programs from the auxiliary screen.
16	There are auxiliary M functions

**COCYF1 (P148)** They allow hiding operations or cycles that are not used and only show the ones being used.

**COCYF5 (P152)**

**COCYZ (P155)**

Each one of these parameters is associated with an operation or cycle and each one of their bits refers to each available level.

This parameter has 16 bits counted from left to right. All the bits are initialized to "0", available option. To hide the desired one, set the corresponding bit to "1".



NEW FEATURES

(SOFT M: 9.0x)

**COCYZ (000000001000110)**

Bit	Meaning
10	It hides the threading cycle.
14	It hides the drilling 3 cycle.
15	It hides the drilling 2 cycle.

**COCYF5 (000000000000010)**

Bit	Meaning
15	It hides the 3D profile pocket cycle.

**COCYF1 (000000000000010)**

Bit	Meaning
15	It hides the PROBE 1 cycle.

The PROBE1 cycle can also be hidden by setting parameters "PRBXMIN (P40)" through "PRBZMAX (P45)" to zero.

## 30.2 PLC program

The PLC program must be modified as follows in order for the machine to work properly with this configuration:

- Stop the machine when the Z axis gets in position and the X-Y axes are going to start moving.
- Disabled the X-Y axes when the axis to be moved is the Z axis.
- Distinguish between the execution status of programs, cycles, jog mode and tool inspection in order to set the Z axis as a dro axis (display only) or not.
- The PLC mark "TOOLINSP" must always be active. Otherwise, when a STOP is generated with the PLC, it goes directly into tool inspection mode.

The PLC program must contain a maneuver for a two-and-a-half-axis configuration and another one for a 3-axis configuration. Switching from one to the other must be automatic depending on the value of "CODISET".

```

;
;***** 2+1/2-AXIS APPLICATION *****
;
() = SET TOOLINSP
= CNCRD(MPG147,R131,M1000)
;
NOT B2R131 = JMP L99          ; If not 2+1/2 axes, go to label L99.
;
() = CNCRD(OPMODA,R130,M1000)
;
NOT B0R130                    ; The program is not in execution.
AND NOT B4R130                ; It is not interrupted.
AND NOT B7R130                ; And it is not in Tool Inspection.
= DRO3                         ; The Z axis is a dro axis.
;
(NOT INPOSX                    ; The X axis is not in position.
OR NOT INPOSY)                ; Or the Y axis is not in position.
AND DFD B3R130                ; Y is coming out of Tool Inspection mode.
= TG1 124 100                 ; Generate /STOP.
;

```



NEW FEATURES

(SOFT M: 9.0x)

---

```

ENABLEZ                ; The Z axis is to be moved.
AND INPOSX              ; And the X axis is in position.
AND INPOSY              ; And the Y axis is in position.
= SET M200              ; The Z axis may be moved.
;
M200                   ; If it is possible to move Z.
AND B0R130              ; And there is a program in execution.
AND NOT B3R130          ; It is not repositioning.
AND NOT B7R130          ; And it is not in Tool Inspection.
= SET INHIBITX           ; Inhibit the X axis.
= SET INHIBITY           ; Inhibit the Y axis.
= MOV 100 R131           ; Set PLC feedrate override to 100%.
= CNCWR(R131,PLCFRO,M9) ; Disable the feedrate override.
;
M200                   ; If it is possible to move Z.
AND B0R130              ; And there is a program in execution.
AND NOT B4R130          ; It is not interrupted.
= M412                  ; The Z axis is moving.
;
M412                   ; If the Z axis is moving.
AND (ENABLEX OR ENABLEY) ; And the X or Y axis is to be moved.
= TG1 123,100           ; Generate /STOP.
;
DFD INCYCLE             ; Program execution has ended or a /STOP has been generated.
= RES M200              ; Z axis movement completed.
;
START AND NOT M412      ; CYCLE START is pressed and the Z axis does not move.
OR DFD B0R130           ; Or program execution is over.
OR DFU B7R130           ; Or it went into tool inspection.
= RES INHIBITX          ; Enable the X axis.
= RES INHIBITY          ; Enable the Y axis.
= MOV 0 R131            ; Set PLC feedrate override to 0%.
= CNCWR(R131,PLCFRO,M9) ; Enable the feedrate override.
;
L99
;
;
;***** Emergency, feedhold, stop, auxend *****
;
NOT T123
AND NOT T124
= /STOP
;
I1 = /EMERGEN           ; E-stop button.
;
/ALARM = O1
;
() = /FEEDHOL
= /XFERINH
;
START AND NOT M412      ; CYCLE START is pressed and the Z axis does not move.
= CYSTART
;
NOT T1 = AUXEND
;

```

---



NEW FEATURES

(SOFT M: 9.0x)



## 31 OEM cycles. Copying a profile

Placing the editing focus on an element set for editing profiles and pressing [↓] expands a list with the profiles available. The following operations are possible on this list.

- See the profiles available ([↑] [↓]).
- Select a profile.
- Delete a profile ([CLEAR]).
- Modify a profile ([RECALL]).
- Copy a profile ([PPROG]).

To exit the list, simply press [←], [→], [ESC], [SHIFT]+[ESC] or any cycle entering key.



## 1 Detected errors

### A.m.p. JERKLIM (P67)

The values recommended in the manual are wrong. The right values are calculated as follows.

Units	Recommended value
mm.	$JERKLIM = 82 * G00FEED / ACCTIME^{**2}$
inch.	$JERKLIM = 2082 * G00FEED / ACCTIME^{**2}$

Use parameter ACCTIME2 when adjusting the second set of parameters.

If the stability of the machine is affected by the values mentioned earlier, the JERKLIM value should be lowered to half as much.

### Variable SSVARS

This variable appears by mistake in the manual under the name of "SVARS"; the right name is "SVARSS".

This variable permits reading or modifying the value of the Sercos variable corresponding to the identifier of the second spindle.

### G2/G3 function programming example (Helical interpolation)

In the programming example, the drawing is wrong. The right example is the following.

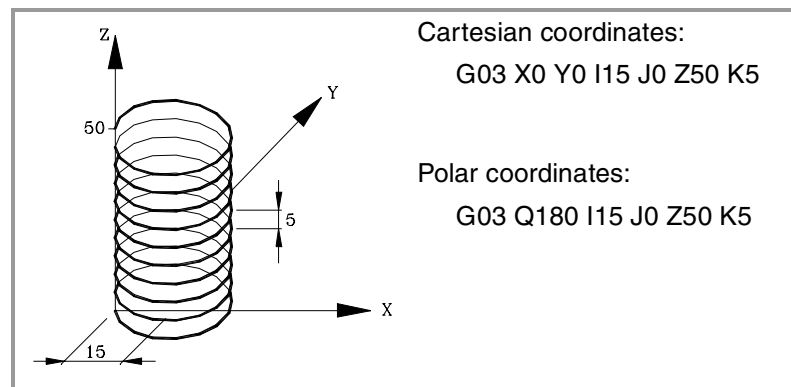

## 2 Heat dissipation. Central Unit enclosure

The temperature of the enclosure for the central unit must not exceed 45°C while the unit is running. To ensure that this temperature is not exceeded, the enclosure must have enough surface to evacuate the heat generated inside and maintain the ambient conditions within the working temperature range.

### Calculating the surface needed to dissipate the heat

The expressions have been obtained for an enclosure whose walls are 2 mm thick and is made out of aluminum. When using internal cooling, the fan is located at 30 mm from the bottom.

To calculate the required total surface of the enclosure in order to dissipate the heat generated in it, the following data must be taken into account.

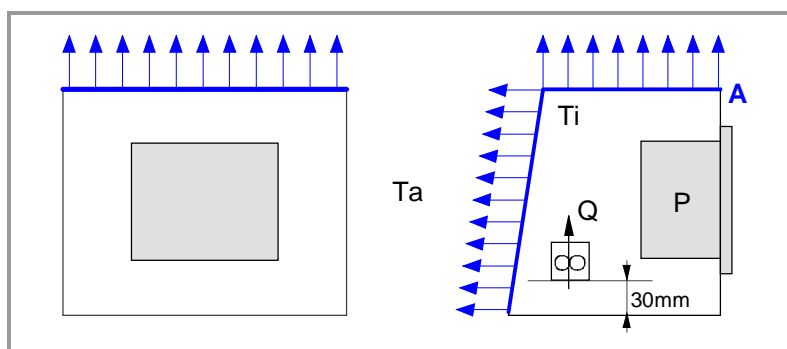

- A (m<sup>2</sup>) Necessary total surface.
- P (W) Total power dissipated by all the elements that generate heat inside the enclosure, including the power supply and the fan if there is one.
- Ta (°C) Ambient temperature or outside the enclosure.
- Ti (°C) Temperature inside the enclosure.
- Δt (°C) Temperature difference (Ti-Ta).
- Q (m<sup>3</sup>/h) Air flow supplied by the fan, if there is one.

### Dissipating surface

Only the top and rear of the enclosure are considered as convection heat dissipating surfaces. The rest of the surfaces will not be considered in the total surface.

### Power dissipated by the CNC

The maximum power dissipated by the 8055(i) CNC is 60 Watts, power supply not included.

## 2.1 Heat dissipation by natural convection

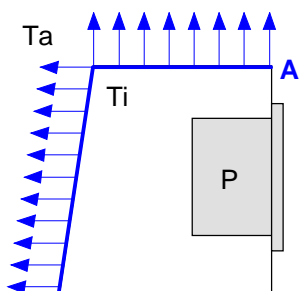

Surface without paint.

$$A = \frac{P}{5 \cdot \Delta T}$$

Surface with smooth metallic enamel.

$$A = \frac{P}{5,7 \cdot \Delta T}$$

## 2.2 Heat dissipation by forced convection with inside fan

Fan whose air flow is  $Q = 13.6 \text{ m}^3/\text{h}$  facing down.

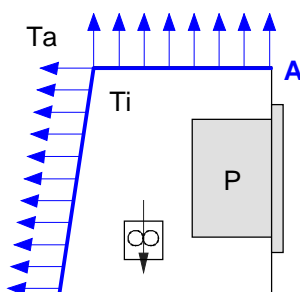

Surface without paint.

$$A = \frac{P}{5,6 \cdot \Delta T}$$

Surface with smooth metallic enamel.

$$A = \frac{P}{7,6 \cdot \Delta T}$$

Fan whose air flow is  $Q = 13.6 \text{ m}^3/\text{h}$  facing up.

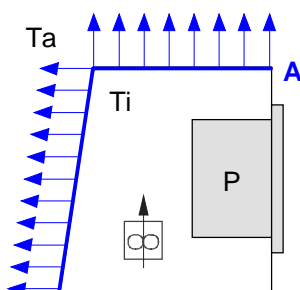

Surface without paint.

$$A = \frac{P}{5,8 \cdot \Delta T}$$

Fan whose air flow is  $Q = 30 \text{ m}^3/\text{h}$  facing down.

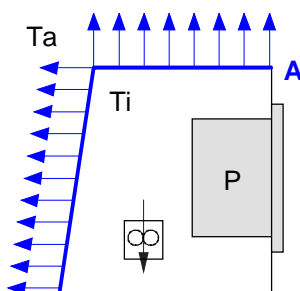

Surface without paint.

$$A = \frac{P}{6,75 \cdot \Delta T}$$

Surface with smooth metallic enamel.

$$A = \frac{P}{9,1 \cdot \Delta T}$$

Fan whose air flow is  $Q = 102 \text{ m}^3/\text{h}$  facing down.

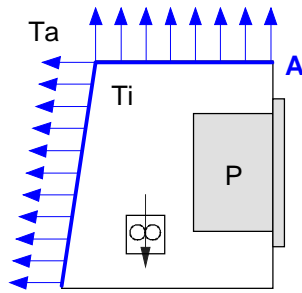

Surface without paint.

$$A = \frac{P}{7,5 \cdot \Delta T}$$

Surface with smooth metallic enamel.

$$A = \frac{P}{9,8 \cdot \Delta T}$$

### 2.3 Heat dissipation by air flow to the outside using a fan

Heat dissipation by convection forcing hot air flow to flow outside with a fan and ambient air input through the holes of the bottom surface of the enclosure.

For this case, calculate the necessary air flow that the fan must supply to dissipate the heat generated inside the enclosure. The fan's air flow is calculated according to the power dissipated by the CNC and the fan itself as well as the inside and outside temperatures.

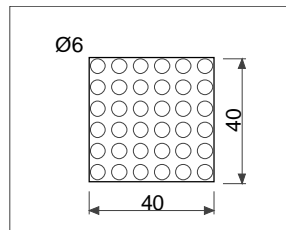

Surface without paint.

$$v = \frac{3,8 \cdot P}{\Delta T}$$

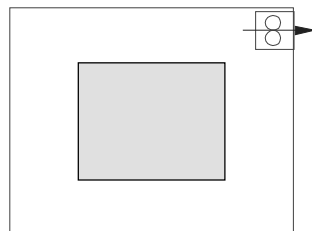

It must be borne in mind that this air flow through the unit allows extracting hot air out, but it may let dust in. A filter should be placed in order to maintain the permitted ambient conditions.

### 3 Can regulation

The Can field bus and the standard Can OPEN communications protocol are now available for communicating with the drives. In general, their characteristics are similar to those of the Sercos ring with lower transmission speed.

This type of regulation is enabled through its corresponding software option. Can regulation is not possible when the CNC has a CPU-Turbo card.

The same system may have Can axes and analog axes. On the other hand, it is not possible to have an axis module with Sercos interface and Can interface at the same time.

#### 3.1 Configuration at the 8055 CNC

- COM1** Connectors for connecting the drives through the Can connection. When it becomes available, the hardware diagnosis screen will identify it as CAN2.
- COM2** Connectors for Can connection with the remote I/Os (optional). When it becomes available, the hardware diagnosis screen will identify it as Can.

#### 3.2 Configuration at the 8055i CNC

The Can connector to communicate with the drives is located in the rear.

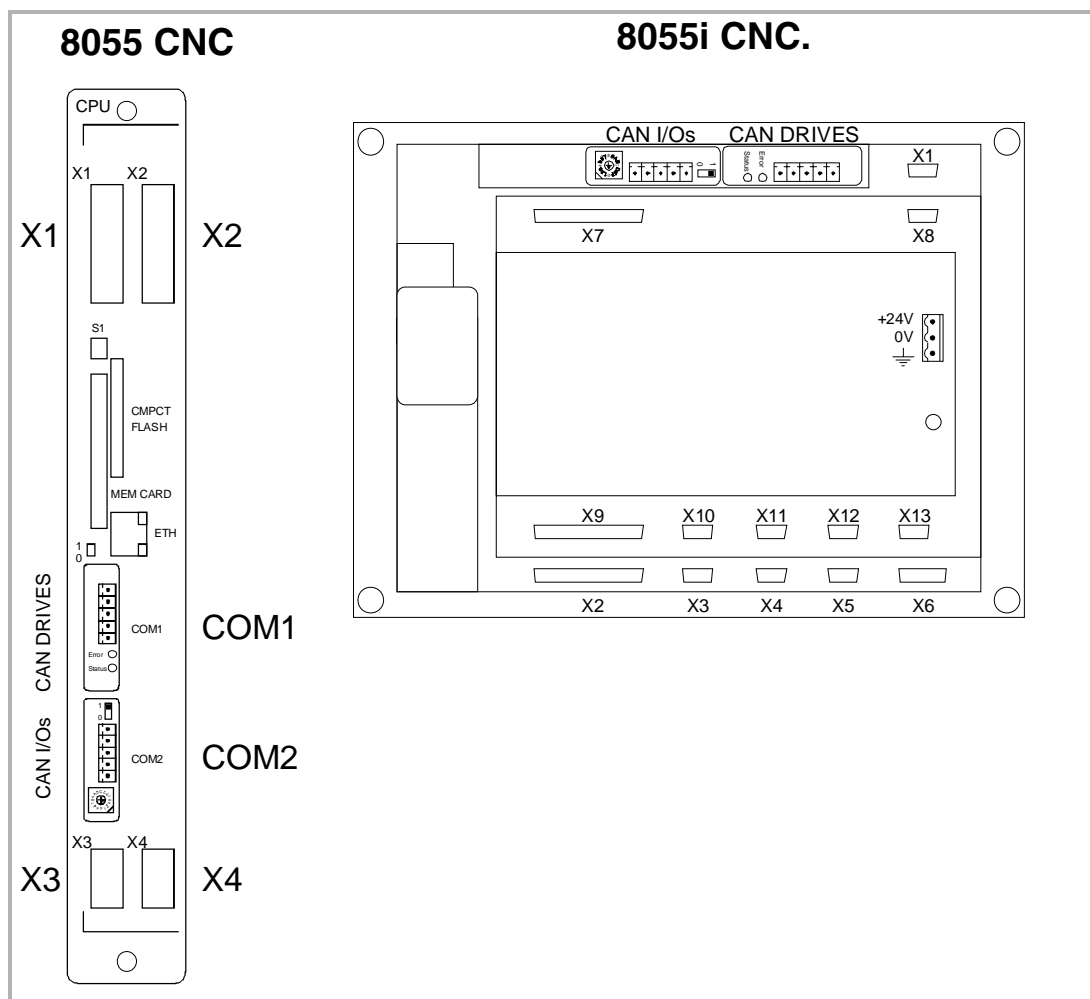

NEW FEATURES

(SOFT M: 9.1x)

**Can connector**

5-pin Open-Style connector.

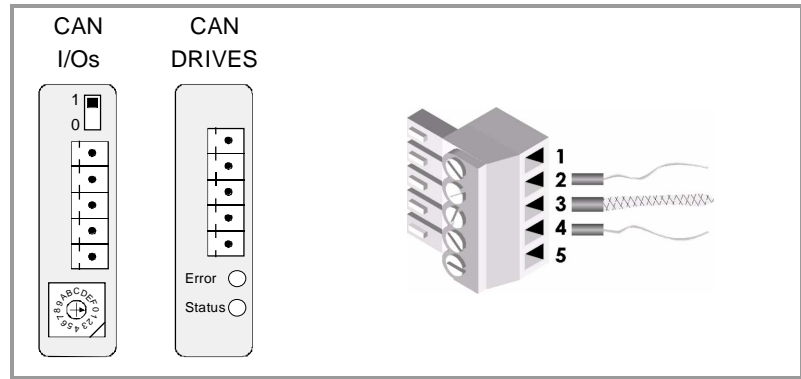

Pin	Signal	Description
1	ISO GND	Not connected
2	CAN L	Can L bus line
3	SHIELD	Overall shield
4	CAN H	Can H bus line
5	SHIELD	Not connected

**Connection with the drives through Can interface.**

It is done through the Can connector of the CNC and each Can connector of the drives.

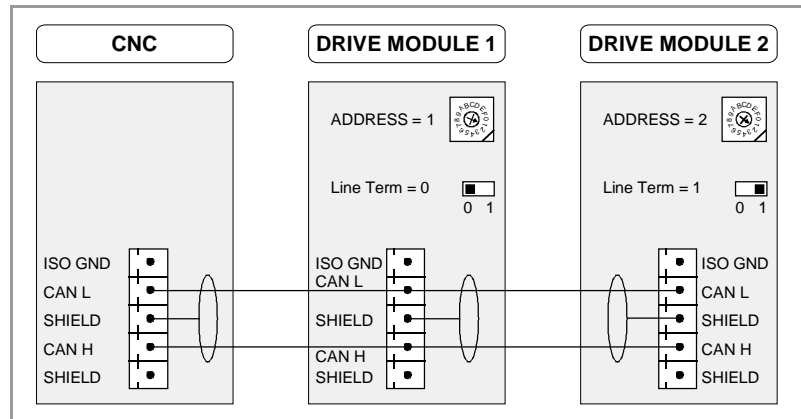

The rotary switch indicates the address (device select) occupied by each element integrated in the Can bus. Although the switch has 16 positions, only positions 1 through 8 are valid.

The CNC does not have a switch and always assumes position 0 inside the bus. The rest occupy consecutive positions (recommended) starting from -1.



NEW FEATURES

(SOFT M: 9.1x)



*Although both Can buses are independent, the Can addresses of the drives cannot be the same as the Can addresses of the I/O modules. If the -1- address is used at the drive's Can bus, there cannot be any module with that address in the CAN bus of the I/O's.*

The corresponding module must be turned off and back on (or press the reset button) for the address change to be assumed.

The elements at the end must have the "Line Term" (terminating resistor) switch in position "1" (ON), the rest in position "0" (OFF). The CNC does not have a switch and always has the terminating resistor activated.



**CAN cable characteristics.**

Use a specific CAN cable. The ends of all the wires and the shield must be protected by the corresponding terminal (pin). Also use the terminals (pins) to secure the cable to the connector.

Type:	Shielded. Twisted pair (1 x 2 x 0.25mm <sup>2</sup> ).
Flexibility:	Extremely flexible. Minimum bending radius, static = 50 mm and dynamic = 95mm.
Cover:	PUR
Impedance:	Cat.5 (100Ω - 120Ω)

**3.3 Can transmission speed selection**

**CANSPEED (P169)** When using Can connection, the transmission speed depends on the length of the cable or total Can connection distance. This g.m.p. sets the transmission speed. The possible values are:

Value	Speed	Maximum distance
0 (By default)	1 Mbit/sec	20 meters
1	800 Kbit/sec	45 meters
2	500 Kbit/sec	95 meters

**3.4 Can address selection**

**DRIBUSID (P56)** Indicates the Can address associated with the axis or the spindle. It corresponds to the node selector switch of the drives that have Can. It is recommended (not necessary) that the Can addresses of the various axes and spindles be consecutive and start from number 1. For example, with 3 Can axes and 1 Can spindle, the values of this parameter could be 1, 2, 3 and 4.

On axes:

Possible values	Meaning
0 (By default)	No-Can axis
1 - 8	Can address

On spindles:

Possible values	Meaning
0 (By default)	No-Can spindle
1 - 8	Can address

On auxiliary spindle:

Possible values	Meaning
0 (By default)	No-Can auxiliary spindle
1 - 8	Can address



*Note that, from version V9.11 on, parameter SERCOSID is now called DRIBUSID. This parameter is applied in the same way whether the communication is Sercos or Can.*

### 3.5 Communication levels via Can

**DRIBUSLE (P63)** The CNC takes this parameter into account when the axis has been assigned a Can address, a.m.p. DRIBUSID (P56) other than "0".

Even when the data exchange between the CNC and the drive is done via Can, one must define whether the feedback is also handled via Can or through the corresponding connector for the axis or spindle. At all levels, the CNC controls the position loop.

<b>DRIBUSLE = 0</b>	The command for the drive is sent out via Can. The axis feedback is done via connector.
The CNC controls the position loop. It is sent via Can:	
<ul style="list-style-type: none"> <li>• Speed</li> <li>• Errors (drive ↔ CNC)</li> <li>• Drive Enable and Speed Enable (CNC → drive)</li> <li>• Some variable (option)</li> </ul>	

<b>DRIBUSLE = 1</b>	The command for the drive is sent out via Can. The axis feedback is done via Can. (motor feedback)
The CNC controls the position loop. All the data between the CNC and the drives is exchanged via Can.	



*Note that, from version V9.11 on, parameter SERCOSLE is now called DRIBUSLE. This parameter is applied in the same way whether the communication is Sercos or Can.*

### 3.6 Spindle gears with Can regulation

To obtain the various speed gears at the spindle, set s.m.p. MAXGEAR of each gear. This parameter is a must for the automatic gear change, etc.

To obtain the different gear ratios, set s.m.p. INPREV and OUTPREV. If DRIBUSLE=1 no gear ratios are possible.



*There is no need to set parameters MAXVOLT(1-4) of the gear as required when using Sercos.*

If parameter NPULSES and parameters INPREV and OUTPREV of all the gears are set with a ·0· value, the CNC will assume the equivalent ones of the spindle drive.

**NPULSES (P13)** This s.m.p. sets the number of encoder pulses when the drive's velocity command is sent out via Can (DRIBUSLE = 0 or 1).

**MAXGEAR1 (P2)** These s.m.p. indicate the maximum spindle speed for each gear. This parameter is a must for the automatic gear change, etc.

**MAXGEAR2 (P3)**

**MAXGEAR3 (P4)**

**MAXGEAR4 (P5)**

When not using all 4 gears, use the lower ones and set the unused ones to the same value as the highest one used.

**INPREV1 (P72)** These s.m.p. indicate the entry speed for each gear.  
**INPREV2 (P74)**  
**INPREV3 (P76)** The equivalent parameter at the drive is NP121.  
**INPREV4 (P78)**

**OUTPREV1 (P73)** These s.m.p. indicate the exit speed for each gear.  
**OUTPREV2 (P75)**  
**OUTPREV3 (P77)** The equivalent parameter at the drive is NP122.  
**OUTPREV4 (P79)**

### 3.7 Setting the feedback resolution of the axes

If parameters NPULSES and PITCHB are set with a -0- value, the CNC will assume the equivalent ones of the corresponding axis drive.

- PITCHB (P86)** This a.m.p. sets the ballscrew pitch when using Can regulation.
- PITCH (P7)** This a.m.p. sets the resolution of the linear encoder when the axis feedback is taken to the CNC (DRIBUSLE=0). It does not define the leadscrew pitch, which is defined with a.m.p. PITCHB (P86).
- NPULSES (P8)** This a.m.p. sets the number of encoder pulses when the drive's velocity command is sent out via Can (DRIBUSLE = 0 or 1). When using a linear encoder, it must be set to -0-.
- ABSOFF (P53)** This a.m.p. will be required when using absolute feedback at the motor encoder.

In order for the CNC to show the position of the axes with respect to the machine reference zero (home), this parameter must be assigned the position value (coordinate) of the machine reference zero with respect to the "zero" of the linear encoder.

Possible values:	$\pm 99999.9999$ mm or $\pm 3937.00878$ inches.
By default:	0.

### 3.8 Communication channels via Can

#### ❑ Synchronized channel

Fast channel, synchronized with the position loop used to transmit the axis control data (speed, feedback, etc.).

At every loop time, the CNC transmits to the drive through this channel the World Control (Speed Enable, Drive Enable, Homing Enable, bit handshake) and the velocity command. The drive transmits to the CNC the Word Status and the position value. The transmitted data depends on a.m.p. DRIBUSLE (P63).

#### ❑ Fast service channel (cyclic channel)

At every loop time, this channel transmits data (basically variables) previously defined by the PLC's read-only machine parameters plc.m.p SRR700 (P28) to SRR739 (P67) and write parameters SWR800 (P68) to SWR819 (P87).

This data is updated via Can at every position loop.

The number of variables defined in this channel is limited depending on the number of axes, on the sampling period selected by g.m.p. LOOPTIME (P72) and on the transmission speed set by g.m.p. CANSPEED (P169). A data overflow causes an error at the CNC.



NEW FEATURES

(SOFT M: 9.1x)

▣ **Slow service channel (service channel)**

This channel sets the reading and writing of variables. It can only be accessed through:

- A high level language block in the part-program
- PLC channel
- User channel

Reading and writing from a part-program or from a user channel:

Read: (P\*\*\* = SVARaxis \*\*)

Write: (SVARaxis\*\* = P\*\*)

Example: (P110 = SVARX 121)

it assigns the value of the X axis variable to the Sercos IDN121 identifier that corresponds to the number of input revolutions.

Reading and writing from the PLC channel:

Read: ... = CNCEX ((P\*\*\* = SVARaxis\*\*\*),M1)

Write: ... = CNCEX ((SVARaxis\*\* = P\*\*\*), M1)

Example: ... = CNCEX (( SVARX 100= P120 ),M1)

it assigns the value of parameter P120 to the X axis variable with Sercos IDN100 (VelocityProportionalGain).

### 3.9 Axis management via Can

This option is available when the drives are connected to the CNC via Can. The following resources are available at the CNC:

- Can status screen (includes I/O's and regulation).
- Error management (distorsions).
- Drive parameter management.

**Can parameter editor**

It displays the tables of the drive parameters that are stored in the "Memkey Card" (Card A) and the sofkeys of the Can axes.

The Can parameters are accessed through the "machine parameters" option on the main menu. If there are axes set as Can, it shows a softkey called "drive parameters". Pressing it permits selecting the axis or spindle and accesses an interface at the CNC that looks like that in the figure:

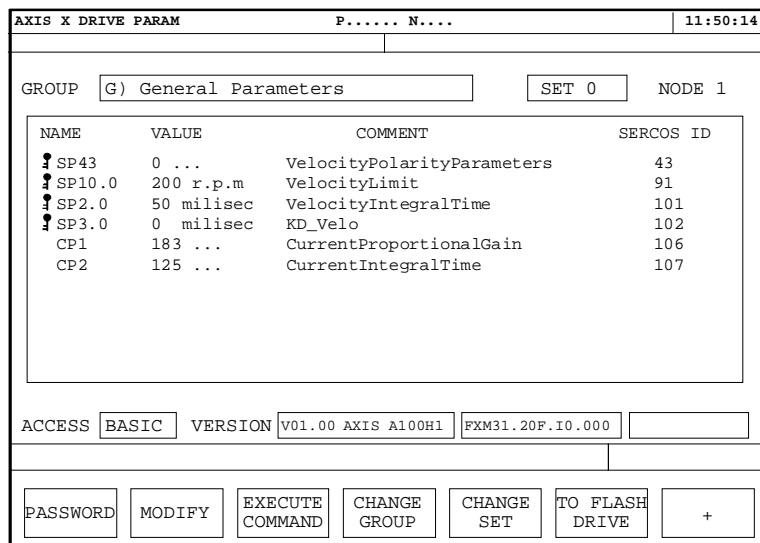

NEW FEATURES

(SOFT M: 9.1X)

**Note:**When selecting the drive parameters at the CNC, it will display the ones stored in each drive and if any are modified, they are modified at the drive. The CNC does not have parameters of the drive although their copies may be stored in the "Memkey Card" (Card A).

Select the group of parameters or variables to display in the **GROUP** window. To change the group, press the [change group] softkey, select the new group with the [↑] [↓] keys and press [ENTER].

Use the **SET** window to select the set of parameters or variables to be displayed. To select another set, press the [change set] softkey, select the new set with the [↑] [↓] keys and press [ENTER].

The **NODE** window indicates the node number that identifies the drive in the Can connection, i.e. the position of its rotary switch.

The main window shows the selected variables or parameters of the group and set indicating in each variable its Fagor name, its value, its meaning and its Sercos identifier.

If the variable does not have a write permission, an icon of a key will appear before the Fagor name.

This information is updated when selecting a new data (group or set), when modifying any variable or parameter and using the "page up and page down" keys. It is not refreshed continuously.

The **ACCESS** window shows the permitted access level. There are three access levels at the drive: basic level, OEM level and Fagor level. To change the level, press the [password] softkey, key in the relevant code and press [ENTER].

The **VERSION** window shows the software version installed at the drive, the name of the motor associated with the drive and the drive model.

The softkeys available in this mode are:

- Password** Modifies the access level selected in the ACCESS window.  
To access the drive parameters with an OEM access level, the password is defined in Utilities mode as OEMPSW; not a preestablished one as when using the Sercos interface.
- Modify** To modify the variables that are not protected (those without the key icon next to them).  
After selecting the variable with the [↑][↓] keys, pressing the "modify" softkey displays two windows. The first one shows the range of possible values and the second one the current value. Enter the new value and press [ENTER].  
The drive assumes that value and refreshes the screen.
- Execute command** Shows the list of commands that can be executed by the drive. Select one using the [↑] [↓] keys and press [ENTER].
- Change group** Select the group of parameters or variables to be displayed.
- Change set** Select the number of the set of parameters or variables to be displayed.
- To drive flash** The drive stores all its parameters in its flash memory and it then executes a soft-reset command. This command interrupts the communication through Can. Press [ENTER] to restore it.



NEW FEATURES

(SOFT M: 9.1x)

**softkey +** Pressing this softkey displays the rest of the softkeys on the screen.

**Save to Card A** It makes a copy of the parameters stored in the RAM memory of the drive into the "Memkey Card" (Card A) of the CNC . It stores them with the name of the axis they are associated with (for example, the X axis parameters).

**Load from Card A** It copies the parameters stored in the "Memkey Card" (Card A) into the RAM memory of the drive with the name of the axis being edited.

**Servo drive errors** It displays a window with the warnings and errors of the drive. If all of them do not fit on the screen, use [↑] [↓].

**Options** It shows a screen where one can select to display either all the parameters and variables or just the ones than can be modified. Press the [modify option] softkey to change it and [ENTER] to validate it. This option is common to all the axes.



*Note that the Can interface looks and handles parameters the same way as the Sercos one. In fact, the file generated with the drive parameters using Can has the same name (DRX, DROY, etc.) as with Sercos and the internal format of the parameters has the same structure (for example, SP1.7 123).*

Refer to the Fagor DDS servo drive manual for all the details on parameters, variables and commands of the drive that appear in the parameter editing window.

Keeping the Sercos ID offers full compatibility at the CNC both for Sercos axes and Can axes as follows:

- The PLC machine parameters are the same.
- The PLC program regarding the access to the fast and slow channels is the same.
- The user programs or screen configuration programs (consumption bars, etc.) are the same.



*This option works fine for spindles with drive version SPD V7.01 or newer. It also works fine for axes with drive version ACSD V1.01 or newer.*

Note that the oscilloscope will only show the data captured in a synchronization at the position loop level.

### 3.10 Limitations of Can axes

In a transmission using Can interface at 1 MHz, the number of elements available in the CAN bus depending on LOOPTIME will be the following:

Looptime	Nr of axes
4 ms.	4 elements (axes + spindles)
5 ms.	5 elements (axes + spindles)
6 ms.	6 elements (axes + spindles)
2 or 3 ms.	Not possible



*Neither the fast channel nor the oscilloscope will be available for a configuration of LOOPTIME = 6ms and 6 axes.*

### 3.11 CNC logic inputs and outputs via Can

The logic inputs and outputs for CNC-PLC communications via CAN are the same as the ones used via Sercos.

#### General logic outputs

**CAXSEROK (M5055)** It must be used on the Lathe model, when the "C" axis and the spindle share the same drive. The PLC sets this signal high to let the CNC know that the drive is ready to work as a "C" axis.

The installation manual shows how to share a drive for the C axis and the spindle.

#### Logic inputs of the axes and spindles

**SPENA  
DRENA**

On the axes, those marks may be defined with the logic number (1 to 7) or name (X-C) of the axis like, for example, SPENA1, SPENAB, DRENA3, DRENAX, etc.

On the spindles, they are defined as follows.

SPENAS    DRENAS    for the main spindle.  
 SPENAS2    DRENAS2    for the secondary spindle.  
 SPENAAS    DRENAAS    for the auxiliary spindle.

The CNC uses these signals when communicating with the drive via Sercos or via Can. Every time the PLC sets one of these signals high, the CNC lets the corresponding drive know about it via Sercos.

These signals correspond to the "Speed enable" and "Drive enable" signals of the drive. The drive manual describes how the two signals work, however, remember the following:

- Both signals must be initialized low when powering up the PLC.
- For normal drive operation, both signals must be set high.
- A down flank (trailing edge) of the DRENA signal (Drive enable) turns off the power circuit of the drive and the motor loses its torque. In this situation, the motor is no longer governed and it will stop when its kinetic energy runs out. (Stop by friction).



NEW FEATURES

(SOFT M: 9.1X)

- A trailing edge of the SPENA signal (Speed enable) switches the "Internal Velocity Reference" to "0" rpm and brakes the motor while maintaining its torque. Once the motor has stopped, it turns off the power circuit of the drive and the motor loses its torque.

## Logic outputs of the axes and spindles

### DRSTAF DRSTAS

On the axes, those marks may be defined with the logic number (1 to 7) or name (X-C) of the axis like, for example, DRSTAF2, DRSTAFc, DRSTAS3, DRSTAFY, etc.

On the spindles, they are defined as follows.

DRSTAFS DRSTASS for the main spindle.  
DRSTAFS2 DRSTASS2 for the secondary spindle.  
DRSTAFAS DRSTASAS for the auxiliary spindle.

The CNC uses these signals when communicating with the drive via Sercos or via Can and indicate the status of the drive.

	DRSTAF	DRSTAS
Actuating the main switch of the electrical cabinet supplies 24 Vdc to the drive.	0	0
The drive runs an internal test. If correct, it activates the output "System OK". From that moment on, the power supply must be turned on.	0	1
When there is power at the drive Bus, it is ready to output torque. To do that, activate the "Drive Enable" and "Speed Enable" inputs.	1	0
Once the "Drive enable" and "Speed enable" are activated, the drive is running properly.	1	1

When an internal error occurs at the drive, the DRSTAF\* and DRSTAS\* signals are set low (logic level low).

## Resources associated with the mnemonics

Each of these CNC logic inputs and outputs may be referred to with the corresponding PLC resource or with their associated mnemonic.

### CAXSEROK (M5055)

SPENA1 (M5110)	DRENA1 (M5111)
SPENA2 (M5160)	DRENA2 (M5161)
SPENA3 (M5210)	DRENA3 (M5211)
SPENA4 (M5260)	DRENA4 (M5261)
SPENA5 (M5310)	DRENA5 (M5311)
SPENA6 (M5360)	DRENA6 (M5361)
SPENA7 (M5410)	DRENA7 (M5411)
SPENAS (M5462)	DRENAS (M5463)
SPENAS2 (M5487)	DRENAS2 (M5488)
SPENAAS (M5449)	DRENAAS (M5448)
DRSTAF1 (M5603)	DRSTAS1 (M5604)
DRSTAF2 (M5653)	DRSTAS2 (M5654)
DRSTAF3 (M5703)	DRSTAS3 (M5704)
DRSTAF4 (M5753)	DRSTAS4 (M5754)
DRSTAF5 (M5803)	DRSTAS5 (M5804)
DRSTAF6 (M5853)	DRSTAS6 (M5854)
DRSTAF7 (M5903)	DRSTAS7 (M5904)
DRSTAFS (M5953)	DRSTASS (M5954)
DRSTAFS2 (M5978)	DRSTASS2 (M5979)
DRSTAFAS (M5557)	DRSTASAS (M5556)



NEW FEATURES

(SOFT M: 9.1X)



In the mnemonics, the numerical suffix (1 to 7) refers to the logic number of the axis; it may be replaced with the name of the axis such as SPENAX, DRENAC, etc.



NEW FEATURES

(SOFT M: 9.1x)

## 4 8055 model. VPP axes module

This module will appear in Diagnosis > Configuration > Hardware with the name of "Axis module 2".

The axis numbering is compatible with the previous module.

Besides controlling the spindle and the axes of the machine, it governs the first 40 digital PLC inputs and 24 digital PLC outputs. This module offers the following features to communicate with the outside world:

- 4 Feedback inputs admitting single-ended and double-ended (differential) TTL signals as well as single-ended 1Vpp sinewave signals.
- 4 Feedback inputs admitting single and double-ended (differential) TTL signals.
- 8 Analog outputs for the servo drives.
- 4 Free differential analog inputs for controlling, monitoring or supervising systems.
- 2 Digital probe inputs.
- 24 Digital outputs ,optocoupled, commanded by the PLC.
- 40 Digital inputs ,optocoupled, read by the PLC.

### Elements

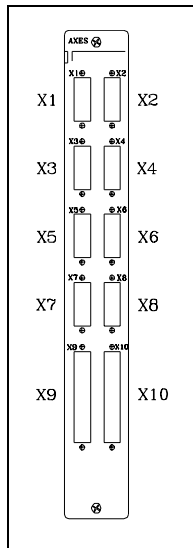

X1 - X2 SUB-D HD type 15-pin female connectors for feedback systems of X3 - X4 each axis. They accept sinewave signals.

X5 - X6 SUB-D type 15-pin male connectors for feedback system of the axes. Up to 2 axes may be connected per connector. They do not accept sinewave signals.

X7 SUB-D type 15-pin male connector to connect up to 4 differential analog inputs (range  $\pm 10V$ ) and two probe inputs (TTL or 24V).

X8 SUB-D type 15-pin female connector to connect up to 8 analog outputs (range  $\pm 10V$ ).

X9 37-pin male connector of the SUB-D type for 32 digital inputs of the PLC.

X10 SUB-D type 37-pin female connector for the 8 digital inputs of the PLC and its 24 digital outputs.



*Do not open this unit. Only personnel authorized by Fagor Automation may open this module.*

*Do not handle the connectors with the unit connected to main AC power. Before manipulating these connectors, make sure that the unit is not connected to main AC power.*



NEW FEATURES

(SOFT M: 9.1X)

### Signal adapters

The following signal adapters are available to be used with the VPP axes module.

SA-TTL-TTLD Adapter for "Non-differential TTL" to "differential TTL" signals

SA-FS-P Adapter for Fagor sinusoidal signal to Vpp signal.

## 4.1 Connectors and connection

### Connectors X1, X2, X3, X4 Differential TTL and 1Vpp sinusoidal feedback signals

They are 25-pin female connectors of the SUB-D HD type and they are used for the feedback system connections of the axes. They admit differential TTL and 1Vpp sinusoidal feedback signals.

It detects overcurrents or short-circuits at the feedback devices issuing the relevant error message.

"Supply voltage error on axis feedback \*\*".

Each connector may be connected to one axis. g.m.p. AXIS1 (P0), AXIS2 (P1), AXIS3 (P2) and AXIS4 (P3) must be set to let the CNC know which axis has been connected to each one of them.

The cable must have overall shielding. The rest of the specifications depend on the feedback system used and the cable length required.

All shields must only be connected to ground at the CNC end leaving the other end free. The wires of the shielded cables cannot be unshielded for more than 75mm (about 3 inches).

It is highly recommended to run these cables as far as possible from the power cables of the machine.

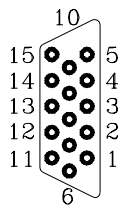
Pin	Signal and Function		
	1	Ac	Differential feedback signals
	2	/Ac	
	3	Bc	
	4	/Bc	
	5	IOc	
	6	/IOc	
	7	ALc	
	8	/Alc	
	9	+5V	+5V output for feedback
	10	+5V	+5V output for the velocity command
	11	GND	0V output for feedback
	12	GND	0V output for the velocity command
	13	----	
	14	----	
	15	Chassis	Shield

When connecting handwheels, they must be differential as well as the axis selector signal. The axis selector signal must be connected to pins 5 and 6.

Non-differential handwheels (for example Fagor 100P) may be connected using either the Fagor signal adapter "SA-TTL-TTLD" (from "non-differential TTL to differential TTL) or connectors X5 and X6.



NEW FEATURES

(SOFT M: 9.1x)

### Connectors X5, X6 **Differential (double-ended) and non-differential (single-ended) TTL feedback signals**

They are 15-pin male connectors of the SUB-D type used for feedback system connections. They admit differential (double-ended) and non-differential (single-ended) TTL feedback.

It detects the error in axis pairs issuing the relevant error message.

"Supply voltage error on axis feedback \*".

Each connector may be connected to up to 2 axes. g.m.p. AXIS5 (P4), AXIS6 (P5), AXIS7 (P6) and AXIS8 (P7) must be set to let the CNC know which axis has been connected to each one of them.

The cables must have overall shielding. The rest of the specifications depend on the feedback system used and the cable length required.

All shields must only be connected to ground at the CNC end leaving the other end free. The wires of the shielded cables cannot be unshielded for more than 75mm (about 3 inches).

It is highly recommended to run these cables as far as possible from the power cables of the machine.

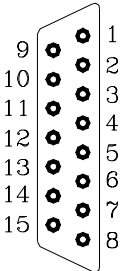
Pin		Signal and Function	
	1	A	Differential squarewave feedback signal.
	2	/A	
	3	B	
	4	/B	
	5	I0	Home signals.
	6	/I0	
	7	+5V	Voltage supply for feedback systems.
	8	0V	
	9	A	Differential squarewave feedback signal.
	10	/A	
	11	B	
	12	/B	
	13	I0	Home signals.
	14	/I0	
	15		Chassis - Shield.

When using a FAGOR 100P model handwheel, the axis selecting signal must be connected to the reference mark (I0) pin of the corresponding axis 5 or 13 of this connector.



NEW FEATURES

(SOFT M: 9.1x)

## Connector X7

### Differential analog inputs and touch probes

It is a 15-pin male connector of the SUB-D type used to connect the two touch probes and the analog inputs.

Up to 4 analog inputs may be connected for supervision, monitoring, etc. The signals may be within a range of  $\pm 5V$  or  $\pm 10V$ .



*The  $\pm 5V$  or  $\pm 10V$  range is selected with the PLC machine parameter "IANA5V".*

There are 4 inputs to connect the probe (two for 5V, and two for 24V); the 0V of the power supply must be connected to the "probe 0V input".

All shields must only be connected to ground at the CNC end leaving the other end free. The wires of the shielded cables cannot be unshielded for more than 75mm (about 3 inches).

Pin	Signal and Function		
	1	I1 +	Positive differential analog inputs.
	2	I2 +	
	3	I3 +	
	4	I4 +	
	5	PROBE1_5V	5V input of probe 1.
	6	PROBE2_5V	5V input of probe 2.
	7	GND	0V input of the probe.
	8		
	9	I1 -	Negative differential analog inputs.
	10	I2 -	
	11	I3 -	
	12	I4 -	
	13	PROBE1_24V	24V input of probe 1.
	14	PROBE2_24V	24V input of probe 2.
	15	+5V	5V supply for the probes.

### Warning:



*The machine manufacturer must comply with the "EN 60204-1 (IEC-204-1)", standard regarding protection against electrical shock due to I/O contact failures with external power supply when not hooking up this connector before turning the power supply on.*

**Connector X8**

**Analog outputs**

It is a 15-pin female connector of the SUB-D type used for the analog servo outputs

Each one of the outputs (O1 thru O8) correspond to the feedback inputs X1 thru X6. The name of the axis connected to each one of them is determined by setting g.m.p. AXIS1 (P0) thru AXIS8 (P7).

All shields must only be connected to ground at the CNC end leaving the other end free. The wires of the shielded cables cannot be unshielded for more than 75mm (about 3 inches).

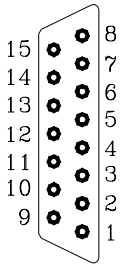
Pin		Signal and Function	
	1	O1	Analog output signals with a range of ±10V.
	2	O2	
	3	O3	
	4	O4	
	5	O5	
	6	O6	
	7	O7	
	8	O8	
	9	GND	Analog voltage reference signals.
	10	GND	
	11	GND	
	12	GND	
	13	GND	
	14	GND	
	15		Chassis - Shield.



NEW FEATURES

(SOFT M: 9.1x)

## Connector X9

## PLC inputs

It is a 37-pin male connector of the SUB-D type used for the PLC inputs.

Since the response time of the EMERGENCY signal must be very short, the CNC has assigned input I1 (pin 2) for this purpose. Thus, the CNC will treat this input immediately regardless of how the PLC program uses it.

The 0V of the power supply used for these inputs must be connected to pins 18 and 19 of the connector.

All shields must only be connected to ground at the CNC end leaving the other end free. The wires of the shielded cables cannot be unshielded for more than 75mm (about 3 inches).

Pin	Signal and Function	
	1	----
	2	I1 / Emergency stop.
	3	I3
	4	I5
	5	I7
	6	I9
	7	I11
	8	I13
	9	I15
	10	I17
	11	I19
	12	I21
	13	I23
	14	I25
	15	I27
	16	I29
	17	I31
	18	0V External power supply.
	19	0V External power supply.
	20	----
	21	I2
	22	I4
	23	I6
	24	I8
	25	I10
	26	I12
	27	I14
	28	I16
	29	I18
	30	I20
	31	I22
	32	I24
	33	I26
	34	I28
	35	I30
	36	I32
	37	Chassis - Shield

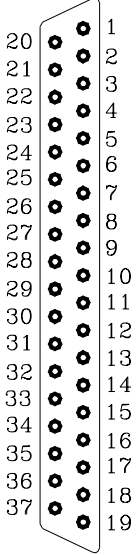

### Connector X10

### CNC logic inputs and outputs.

It is a 37-pin female connector of the SUB-D type used for the inputs and outputs of the PLC.

When an error is issued, the CNC, besides indicating it to the PLC, activates output O1 (pin 2) of this connector. This way, regardless of how this signal is treated by the PLC program, the electrical cabinet can process this signal immediately.

Both 24V and 0V of the power supply used to power these I/Os must be connected to pins 18 and 19 (for 0V) and pins 1 and 20 (for 24V).

All shields must only be connected to ground at the CNC end leaving the other end free. The wires of the shielded cables cannot be unshielded for more than 75mm (about 3 inches).

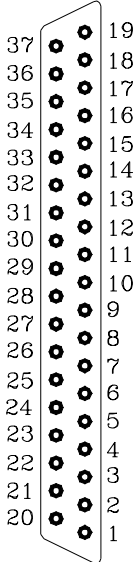
Pin		Signal and Function		
	1	24V	External power supply. / Emergency output.	
	2	O1		
	3	O3		
	4	O5		
	5	O7		
	6	O9		
	7	O11		
	8	O13		
	9	O15		
	10	O17		
	11	O19		
	12	O21		
	13	O23		
	14	I33		
	15	I35		
	16	I37		
	17	I39		
	18	0V		External power supply.
	19	0V		External power supply.
	20	24V		External power supply.
	21	O2		
	22	O4		
	23	O6		
	24	O8		
	25	O10		
	26	O12		
	27	O14		
	28	O16		
	29	O18		
	30	O20		
	31	O22		
	32	O24		
	33	I34		
	34	I36		
	35	I38		
	36	I40	Chassis - Shield.	
	37			



NEW FEATURES

(SOFT M: 9.1x)



## Warning:



The Emergency output, which coincides with O1 of the PLC, will be activated (change from logic level 1 to 0) when an ALARM or ERROR occurs at the CNC or when the PLC output O1 is set to 0 (logic level 0).

The machine manufacturer must comply with the "EN 60204-1 (IEC-204-1)", standard regarding protection against electrical shock due to I/O contact failures with external power supply when not hooking up this connector before turning the power supply on.

## 4.2 Technical specifications

+5V power consumption. 1A (250 mA each axis)

Work levels for differential square signal.

Maximum frequency: 400 KHz

Maximum separation between flanks: 460ns.

Phase shift  $90^\circ \pm 20^\circ$

Vmax. in common mode:  $\pm 7V$ .

Vmax. in differential mode:  $\pm 6V$

Hysteresis: 0.2 V

Maximum differential input current: 3mA.

Work levels for non-differential square signal.

Maximum frequency: 400 KHz

Maximum separation between flanks: 460ns.

Phase shift  $90^\circ \pm 20^\circ$

High threshold (logic level 1)  $1.25V < V_{IH} < 7V$ .

Low threshold (logic level 0)  $-7V < V_{IH} < 1V$ .

Vmax.  $\pm 7V$

Hysteresis: 0.25 V

Maximum input current: 3mA.

Work levels for sinusoidal signal.

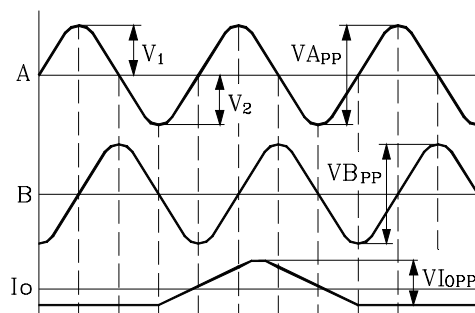

Maximum frequency: 250 KHz

A and B signals

Amplitude:  $0.6 \div 1.2V_{pp}$

Centered:  $|V_1 - V_2| / 2V_{pp} \leq 6.5\%$

Relationship:  $V_{App} / V_{Bpp} = 0.8 \div 1.25$

Phase shift:  $90^\circ \pm 10^\circ$

Reference mark (I0)

Amplitude:  $0.2 \div 0.85V$

Width:  $T-90^\circ \leq I_0 \leq T+180^\circ$

### 4.3 Configuration. Machine parameters

**IANA5V (P130)** This new PLC parameter is used to apply a measuring range at the analog inputs of connector X7 of  $\pm 10V$  instead of  $\pm 5V$ .

The first four bits from the left indicate the 4 analog inputs of the new axis module. The rest of the bits are not being used at this time. By default, the value of the parameter will be 1111000000000000.

When the bit is set to 1, it means that the range is  $\pm 5V$  and if set to 0, it means that the range is  $\pm 10V$ .

Bit	Hardware
1	Analog input 1 to $\pm 5V$ .
2	Analog input 2 to $\pm 5V$ .
3	Analog input 3 to $\pm 5V$ .
4	Analog input 4 to $\pm 5V$ .

**DIFFBACK (P9)** The feedback connectors of the first 4 axes are differential TTL and 1Vpp. The axis machine parameter DIFFBACK is ignored for these axes. Use Fagor signal adapter "SA-TTL-TTLD" (from "non-differential TTL" to "differential TTL") to connect non-differential signals to these connectors.

### 4.4 Modified variables

**HARCOA** It indicates, with bits, the CNC's hardware configuration. The bit will be "1" when the relevant configuration is available.

Bit	Hardware
0	Axis module 2

**ANAI(n)** It returns the value of the indicated analog input (n) and one of the four CNC's analog inputs may be selected. Its value is given in tenth-thousandths of a volt.

Accessing variables ANAI5 through ANAI8 will issue the relevant error message.

'Access to a variable with wrong index'.

## 5 8055i model. New axis board

This module will appear in Diagnosis > Configuration > Hardware with the name of "Axes 2".

This board includes the recognition of the 24V at the inputs and outputs. They admit differential TTL and 1Vpp sinusoidal feedback signals.



*The new boards are compatible with previous software versions, but they will not recognize the 24V at the inputs and outputs.*

### Protections

Overcurrent or short-circuits are detected in the feedback supply of each axis. The CNC will issue the corresponding error:

"Supply voltage error on axis feedback \*".

### Signal adapters

The following signal adapters are available.

SA-TTL-TTLD Adapter for "Non-differential TTL" to "differential TTL" signals

SA-FS-P Adapter for Fagor sinusoidal signal to Vpp signal.

### 5.1 Modified variables

**HARCON** It indicates, with bits, the CNC's hardware configuration. Bits 7, 8, 9 indicate the type of axis board.

xxxx xxx(9) (8)(7)xx xxxx

Bit 9	Bit 8	Bit 7	
1	0	1	"Axes 2" board, feedback + I/Os
1	1	0	"Axes 2" board, feedback only
1	1	1	"axes 2" board only I/O's

## 6 Hardware associated with the compact flash

The HARCOA variable indicates whether the CNC has a connector to insert a compact flash or not. It does not indicate whether the compact flash is inserted or not.

In Diagnosis > Configuration > Hardware, if the compact flash is not inserted, it will display "HD( 0)". If the compact flash is inserted, but it does not have the hard disk option, it will show "HD( 0 MB)".

**HARCOA** It indicates, with bits, the CNC's hardware configuration. The bit will be "1" when the relevant configuration is available.

Bit	Hardware
0	Axis module 2.
1	It has a connector for compact flash.



NEW FEATURES

(SOFT M: 9.1x)

## 7 Automatic keyboard type identification

From this version on, it detects the type of keyboard that is connected to the CNC and automatically updates the g.m.p. CUSTOMTY (P92).

This feature is only valid with keyboards having the auto-identifying hardware. In the rest of the cases, g.m.p. CUSTOMTY (P92) must be set manually.

If an auto-identifying keyboard is connected to a CNC that has an older software version, the keyboard will beep. In this case, disable the auto-identification hardware of the keyboard by setting the identification switch to zero.

If the keyboard does not match the CNC model, it shows the relevant error message and it loads the key codes that correspond to the CNC model. The error shown will be "the keyboard type does not match the CNC model"

For example, if a mill model keyboard is connected to a lathe CNC, the keyboard has been set for a lathe and the CNC shows the error message.

**KEYIDE** This variable indicates the keyboard code. Is read-only from the CNC, DNC and PLC.

KEYIDE	CUSTOMY (P92)	Keyboard
0		Keyboard without auto-identification.
130	254	Mill model keyboard.
131	254	Lathe model keyboard.
132	254	Conversational mill model keyboard.
133	254	Conversational lathe model keyboard.
134	254	Educational model keyboard.

### Keyboards having auto-identification

For the 8055i CNC.

CNC 8055i/B-M-COL-K	CNC 8055i/C-M-COL-K
CNC 8055i/B-M-MON-K	CNC 8055i/C-M-MON-K
CNC 8055i/B-T-COL-K	CNC 8055i/C-T-COL-K
CNC 8055i/B-T-MON-K	CNC 8055i/C-T-MON-K
CNC 8055i/B-MC-COL-K	CNC 8055i/C-MC-COL-K
CNC 8055i/B-MC-MON-K	CNC 8055i/C-MC-MON-K
CNC 8055i/B-TC-COL-K	CNC 8055i/C-TC-COL-K
CNC 8055i/B-TC-MON-K	CNC 8055i/C-TC-MON-K

For the 8055 CNC.

NMON.55M.11.LCD	NMON.55MC.11.LCD
NMON.55T.11.LCD	NMON.55TC.11.LCD



NEW FEATURES

(SOFT M: 9.1x)

## 8 Sharing the CNC's hard disk with password via FTP

It is possible to share the CNC's hard disk with restrictions requiring a password to access the information. The password is set with the machine parameters for the HD/ETHERNET.

**CNHDPAS1 (P7)** Password for accessing the hard disk from the network. Up to a 14 characters may be used.

**DIRIP (P24)** CNC's IP address.

### Connection from a PC

The easiest way to access the CNC's hard disk from a PC is configuring a new connection.

#### Connection using Windows® 95 or 98.

At the Web browser (e.g. Internet Explorer) or from the file explorer (only on Windows 98), write in the command line the CNC's IP address.

For example: `ftp://cnc:password@10.0.17.62`

#### Connection using Windows® 2000 or XP.

At the file explorer, select My Network sites > Add network sites. It will show the Windows help to add network sites that permits configuring the connection step by step. Press the –OK– button to go on to the next step.

Follow the instructions shown on the screen to configure the connection; refer to the Windows help for additional information.

Define the following data in each step.

1. First, select the network site, in this case an ftp folder.

Write "`ftp://`" followed by the CNC's IP address defined by machine parameter DIRIP (P24).

For example: `ftp://10.0.17.62`

2. Define the user name and the type of session start. As opposed to the case of a hard disk without password, in this case the session is not started anonymously.

The user must identify itself and it must be as "`cnc`" or "`CNC`".

3. Define the name to be associated with the new connection. This is the name that will appear on the PC's net directory. Just select it from the list to start the connection.

For example: `CNC_8055`

After the configuration is done and every time the connection is made, a window will open requesting the user name and password. As user, select "`cnc`" and as password the one defined by machine parameter CNHDPAS1 (P7).

To make it easier, the –Save password– option may be selected in this window. This way, it will no longer request the password when connecting again and it will access the hard disk directly.



NEW FEATURES

(SOFT M: 9.1X)

## 9 Improved telediagnosis

There are two additional ways to connect the CNC with the remote PC; through a direct telephone call and through the internet.

In telediagnosis, when making a direct call, the CNC end incurs the expense of the call because it is the element establishing the connection with the PC. In telediagnosis, through the internet, both the CNC and the PC must be connected to the internet.

Telediagnosis through the Internet offers all the advantages of this type of connection. Usually, this type of connection costs less than a direct telephone call. When connecting through the Internet for the connection, the telediagnosis may sometimes be slower than making a direct telephone call.

### 9.1 Telediagnosis through the Internet

To telediagnose through the Internet, both the CNC and the PC involved must be connected to the Internet.

#### CNC connection

The modem must be connected to the CNC's serial line.

Go to the screen Status > DNC > Telephone call and press the "INTERNET" softkey. The window for the telephone call will display the fields "User" and "Password".

To make the connection, fill out at least the telephone, user and password fields. This data is supplied by the Internet connection provider. The user name and the password may be up to 15 characters long.

Once the fields have been filled out, press the "DIAL UP" softkey. Once the connection has been made, the bottom of the screen will show the IP address. This address must be communicated to the person who is going to telediagnose from the PC.

## PC connection

There are many ways to connect the PC to the Internet, through a modem, LAN, ADSL, etc. If it is connected through a firewall (safety filters for the connection), it may have to be configured so it lets the Fagor telediagnosis data through. These communications are established through the TCP/IP 3873 port.



*Connecting through a modem leaves an open way to the local network of the PC. Having this open way may let an undesired third party access the local network.*

*To prevent undesired access, the PC must be disconnected from the local network during telediagnosis.*

Once the PC is connected to the Internet, Create a new configuration at the WinDNC. In the "Type" field, select "Network Node" and the IP address that the CNC offers on the screen.

Press "OK" to finish creating the configuration and "Connect" to connect to the CNC.



*The Internet connection is unidirectional (one way). The WinDNC can receive and send files, enter into telediagnosis or carry out any operation. Nothing can be done with the DNC at the CNC.*

## 9.2 Advanced direct telephone call

Versions V9.01 and V10.01 implemented the telephone call from the CNC. This version offers the possibility to make a new type of connection called "advanced". It makes telediagnosis much faster than in the previous case.

The operating system of the PC must be Windows 2000 or XP.



*This type of telediagnosis uses a standard Windows protocol which like other packs involves opening a communications port at the PC (incoming connection). Having this open port may let an undesired third party access the PC and even the local network.*

*To prevent undesired access, the PC must be disconnected from the local network during telediagnosis; once telediagnosis has concluded, the incoming connection must be disconnected.*

### Configuration of an incoming connection at the PC.

First, configure the PC to accept telephone calls.

In the "Configuration" option of the "Start" menu, select "Network connections" and chose the option for creating a new connection. It will show the Windows help to create connections that permits configuring the connection step by step. Press the –OK– button to go on to the next step.

Follow the instructions shown on the screen to configure the connection; refer to the Windows help for additional information.

Define the following data in each step:

1. The first step is to select the type of network connection that must accept incoming connections. Depending on the operating system of the PC (Windows 2000 or XP) the first steps will be different.

On Windows 2000, select the option "Accept incoming connections".

On Windows XP, first select the option "Configure an advance connection" and, in the next step, the option "Accept incoming connections".

- Then, select and configure the device through which to connect, in this case the modem. To select it, activate the selection box next to the device.

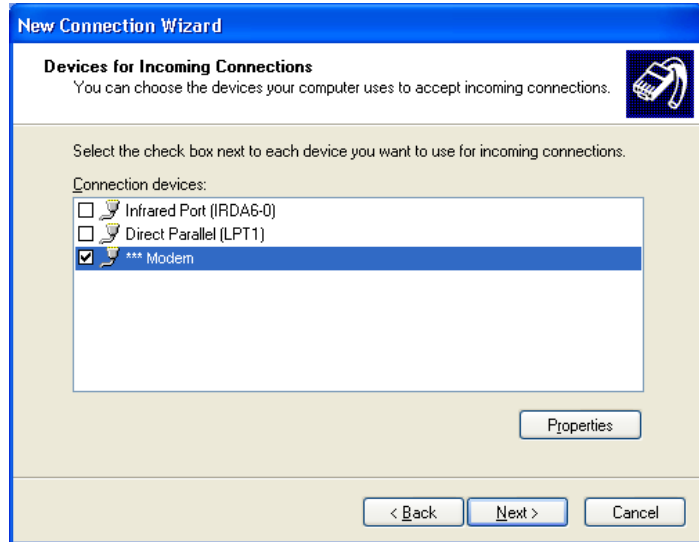

*To prevent undesired access to the PC, once telediagnosis has concluded, the modem must be disabled. To do that, deactivate the selection box next to the device.*

To configure the modem, select the properties button. A window will appear with the connection preferences. If necessary, refer to the documentation of your modem for the proper configuration. As an example, the following values may be used.

On the "Properties" tab (the values are as examples).

Cancel the call if not connected in ... (sec)	60 sec
Port speed	115200
Data protocol	Standard EC
Compression	Enabled
Flow control	Hardware

On the "Advanced" tab (the values are as examples).

Data bits	8
Parity	None
Stop bits	1
Modulation	Standard

If it offers the option to display the window for the dialing terminal, select the options so it is not shown in any case.

- The next step refers to the virtual connections. Choose the option "Do not allow private virtual connections".
- To make the connection, define the users allowed to connect with the PC. The window shows a list of users. To define a new user, press the –Add– button.

To add a new user, define the name, the password and password confirmation. The "Full name" field is optional.



5. The last step consists in configuring the network components. In this case, we'll use the Internet protocol TCP/IP.

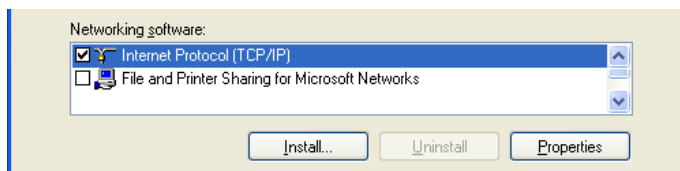

Select the TCP/IP protocol from the list of components and press the properties button.

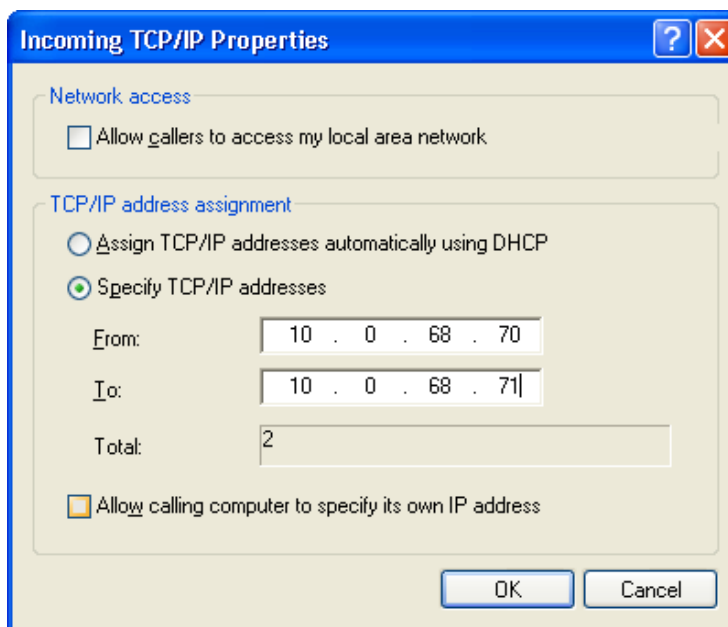

Indicate the TCP/IP addresses. Enter in the "From" field an address that belongs to the local network where the PC is and in the "For" field the next one.

For safety, deselect the option that lets the caller access the local network.



*For example, if the network the PC is in uses 10.0.xx.xx type addresses, the "From" field may use the address 10.0.680.70 and the "For" the next one, i.e. 10.0.680.71, if they are not being used.*

6. Define the name by which the new connection must be recognized. This is the name that will appear on the PC's net directory. Just select it from the list to start the connection.

## How to operate at the CNC

Go to the screen Status > Dnc > Telephone Call and press the "ADVANCED" softkey. The window for the telephone call will display the fields "User" and "Password".

To make the connection, fill out at least the telephone, user and password fields. The user name and the password must be provided by the person doing the telediagnosis who must also have the PC configured to accept incoming connections. The user name and the password may be up to 15 characters long.

Once the fields have been filled out, press the "DIAL UP" softkey.

## How to operate at the PC

While the CNC is dialing, the task bar will show an icon indicating the telephone access connection. At that moment, a new configuration must be created at the WinDNC. Select "Network Node" in the "Type" field and as IP address the one previously configured (in our example 10.0.68.71).

Press "OK" to finish creating the configuration and "Connect" to connect to the CNC.



*The advanced telephone connection is unidirectional (one way). The WinDNC can receive and send files, enter into telediagnosis or carry out any operation. Nothing can be done with the DNC at the CNC.*

### 9.3 Disconnecting the CNC from the Ethernet network during telediagnosis

When making an advanced call or to the Internet, and for safety reasons, the user may temporarily disconnect the CNC from the Ethernet network.

Pressing the "Dial up" softkey opens a new window for disconnecting the CNC from the Ethernet network. The CNC will connect to the Ethernet network again when the call ends.

When the CNC disconnects from the Ethernet network, the Ethernet status screen will show the message "Ethernet not running".

The option to disconnect the CNC from the Ethernet network is only available when having the Ethernet option integrated into the CPU module. This possibility is not offered if the Ethernet option is integrated into the hard disk module.

ETHERNET		P..... N....		DNC		12:24:55	
NET							
MAC	00:0B:CB:10:00:10	MASK	255.255.0.0				
DIRIP	10.0.17.70	GATEWAY					
ETHERNET NOT RUNNING							
RECEPCION							
Packs	767	Errors	0	Lost	0		
Overrun	0	Frame	0				
TRANSMISION							
Packs	1980	Errors	0	Lost	0		
Overrun	0	Collisions	1	Carrier	0		
FTP Active							
REMOTE HARD DISK Active							
						CAP	INS



NEW FEATURES

(SOFT M: 9.1x)

## 10 Modified variables

**HARCOA** It indicates, with bits, the CNC's hardware configuration. The bit will be "1" when the relevant configuration is available.

On the 8055 model:

xxxx xxxx xxxx xx(1)(0)

Bit	Hardware
0	Axis module 2.
1	It has a connector for compact flash.

**HARCON** It indicates, with bits, the CNC's hardware configuration.

On the 8055i model:

Bits 7, 8, 9 indicate the type of axis board.

xxxx xxx(9) (8)(7)xx xxxx

Bit 9	Bit 8	Bit 7	
1	0	1	"Axes 2" board, feedback + I/Os
1	1	0	"Axes 2" board, feedback only
1	1	1	"axes 2" board only I/O's

**HANDSE** For handwheels with axis selector button, it indicates whether that button has been pressed or not.

Value	Meaning
0	The handwheel's axis selector button has not been pressed.
1	The handwheel's axis selector button has been pressed.

This variable may be read from the CNC and from the PLC. Valid for both axis board models.

**SELPRO** When having two probe inputs, it allows selecting the active probe input.

On power-up, it assumes the value of "1" thus selecting the first probe input. To select the second probe input, set it to a value of "2".

Value	Meaning
1	It selects the first probe input.
2	It selects the second probe input.

This variable is read-write from the CNC and PLC and read-only through DNC. Accessing this variable from the CNC interrupts block preparation.

**ANAI(n)** It returns the value of the indicated analog input (n). Its value is given in tenth-thousandths of a volt.

On the 8055 model having the VPP axis board, it is possible to select one of the four that are available. Accessing variables ANAI5 through ANAI8 will issue the relevant error message.

'Access to a variable with wrong index'.

## 11 Changes in tool radius compensation

### 11.1 Change of type of compensation (G41-G42) while machining

When changing the type of compensation, the different cases are solved according to these criteria:

**A.** The compensated paths cut each other.

The programmed paths are compensated each on its corresponding side. The change of sides takes place at the intersection point of both paths.

**B.** The compensated paths do not cut each other.

An additional section is inserted between the two paths. From the point perpendicular to the first path at the end point up to the point perpendicular to the second path at the starting point. Both points are located at a distance R from the programmed path.

Here is a summary of the different cases:

❑ Changing sides straight - straight:

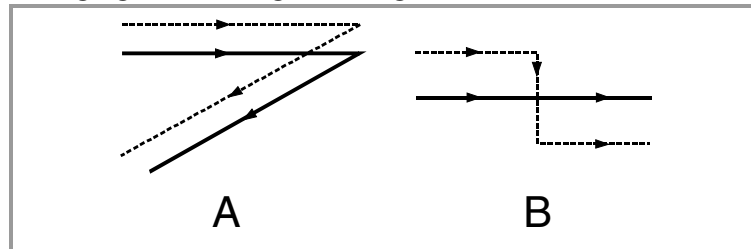

❑ Changing sides straight - arc:

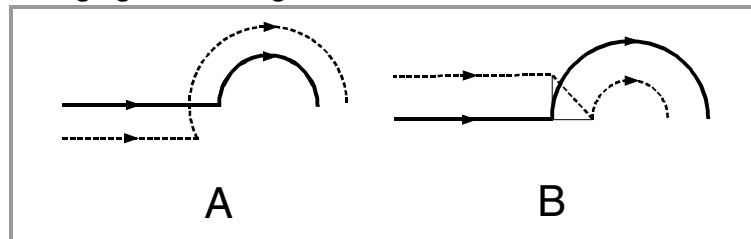

❑ Changing sides arc - straight:

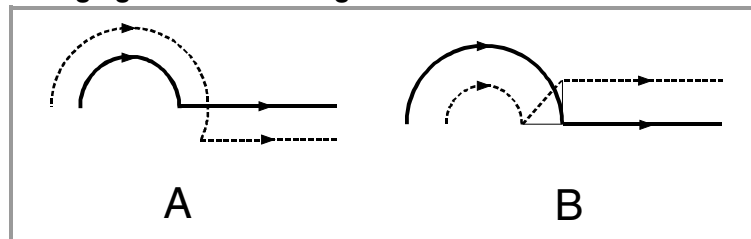

❑ Changing sides arc - arc:

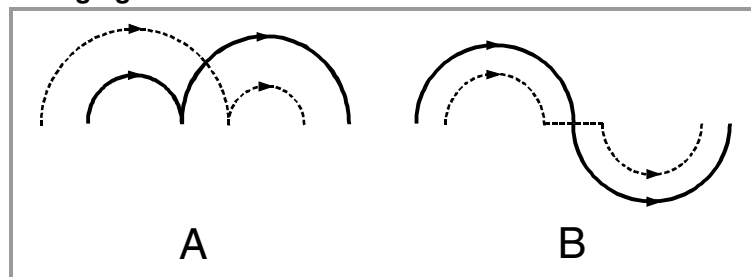

## 11.2 New tool radius compensation modes.

**COMPmode (P175)** It defines how to apply the compensation. The angle  $\alpha$  indicates the angle between paths.

### COMPmode = 0

It applies the compensation like until now.

### COMPmode = 1

It always compensates by joining both paths with arcs.

### COMPmode = 2

For paths in an angle of up to  $300^\circ$ , it is solved by calculating the intersection between compensated paths. If there is no intersection or if the angle  $\alpha$  is greater than  $300^\circ$ , it is solved in the same way as for COMPmode = 0.

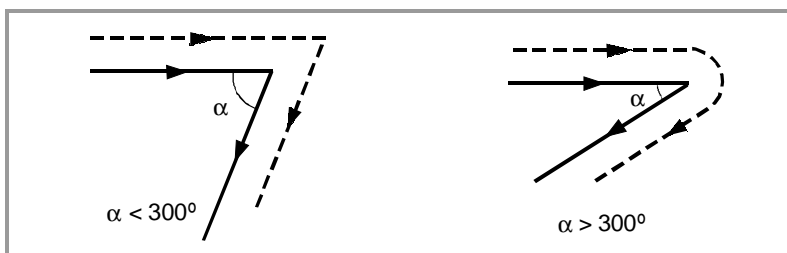

### Compensation diagrams for COMPmode=1

Here are some cases having COMPmode=1, depending on the angle  $\alpha$ .

#### Beginning of compensation straight - straight:

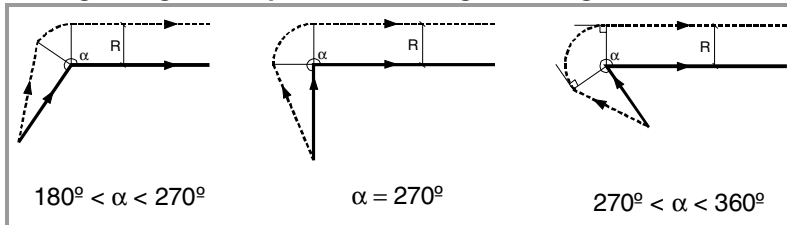

#### Beginning of compensation straight - arc:

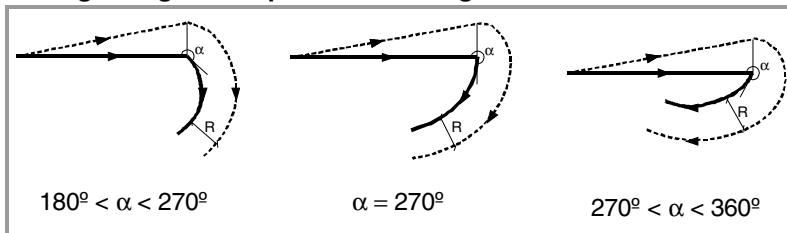

#### Compensation straight - straight:

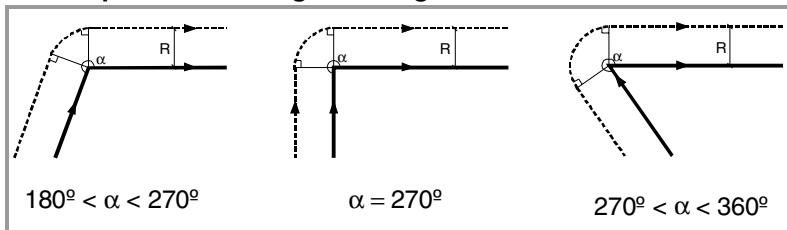

□ Compensation straight - arc:

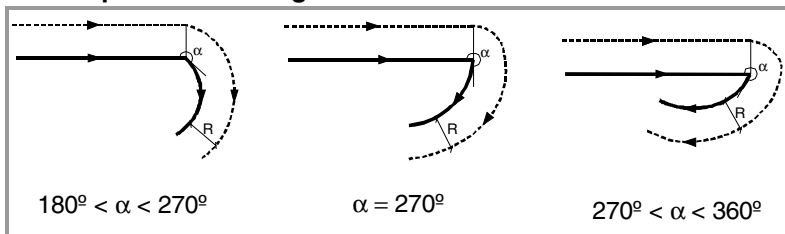

□ Compensation arc - straight:

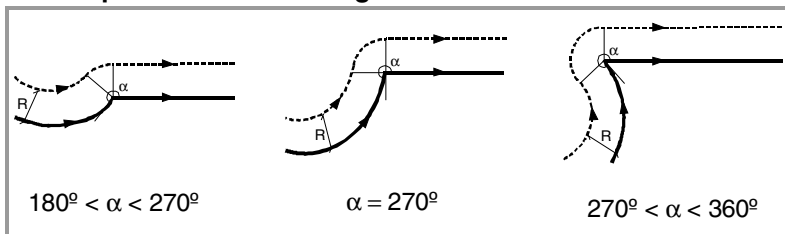

□ Compensation arc - arc:

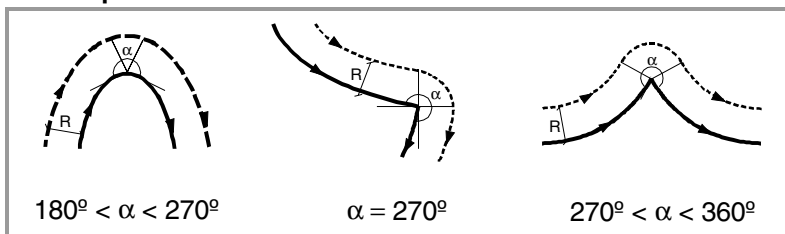

□ End of compensation straight - straight:

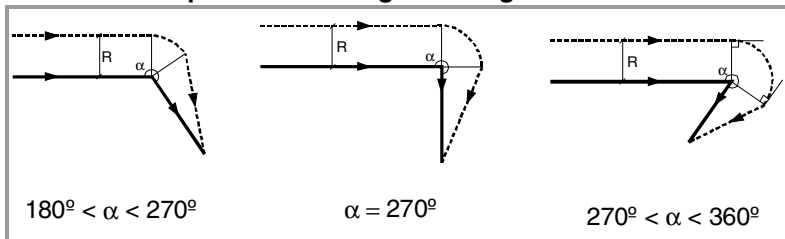

□ End of compensation arc - straight:

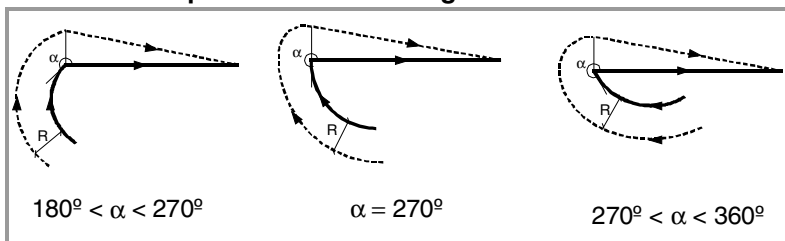

### 11.3 Improvements in tool radius compensation

#### COMTYPE (P74)

From this version on, this g.m.p. has three digits.

- The units set the type of beginning/end of tool radius compensation applied by the CNC.
  - xx0 It approaches the starting point going around the corner
  - xx1 It goes directly perpendicular to the point (without going around the corner)

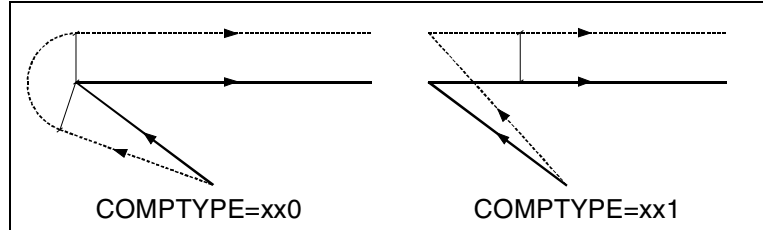

- The tens indicate whether the additional compensation block is executed at the end of the current block or at the beginning of the next block with compensation.
  - x00 It is executed at the end of the current block.
  - x10 It executes the beginning of the next block with compensation.

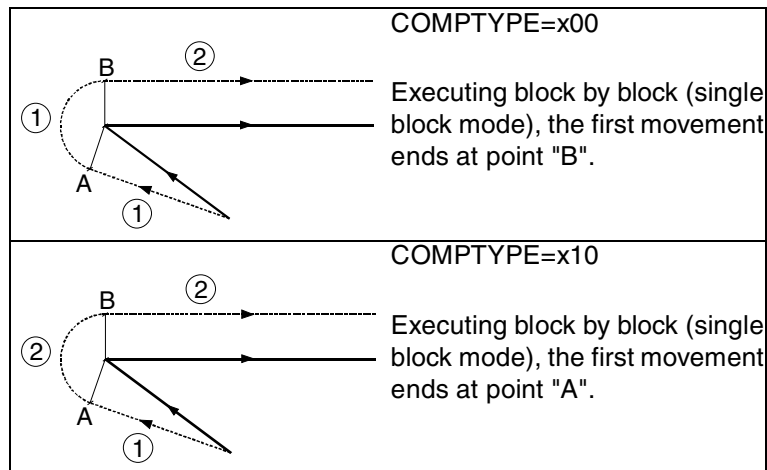

- The hundreds indicate whether the compensation is activated in the first motion block or not, even if the plane axes are not involved. It is also applied when the compensation is canceled.

After activating the compensation, it could happen that the plane axes do not get involved in the first motion block either because they have not been programmed or because the same point as the tool position has been programmed.

In this case, the compensation is applied at the tool position as follows. Depending on the first movement programmed in the plane, the tool moves perpendicular to the path to its starting point.

- 0xx The compensation is activated in the first block having a movement of the plane axes.
- 1xx The compensation is activated in the first motion block even if there is no movement of the plane axes. For example, when programming the same point twice or a zero incremental movement.

The first movement programmed in the plane may be linear or circular.



NEW FEATURES

(SOFT M: 9.1x)



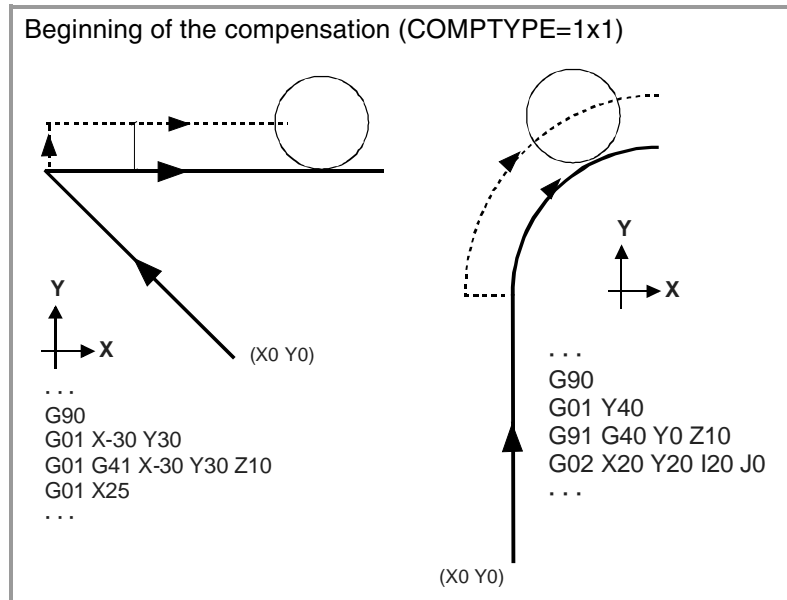

## 12 Improved retracing

The retracing function has been modified as follows:

- New value (2) for g.m.p. RETRACAC.  
If RETRACAC=2, only function M0 is sent out to the PLC; the rest of M functions are not sent to the PLC. They are not executed and retracing is not interrupted. The M0 is executed and [START] must be pressed.  
If RETRACAC=1, it works as until now; i.e. it stops retracing on the M functions.
- The number of blocks being retraced has been increased from 50 to 75.
- Parameter RETRACAC is initialized with SHIFT/RESET. In previous versions, it was initialized with RESET.

## 13 Improved Look-Ahead. It allows G74, G75 and G76

From this version on, it will not issue the error "Incompatible G functions" when executing a home search block (G74) or probing blocks (G75, G76) while Look-Ahead is active.

## 14 Keep G46 while searching home.

When homing the axes that are not involved in the incline axis transformation, function G46 is not canceled.

G46 is only canceled when homing an axis defined by machine parameters ANGAXNA (P171) and ORTAXNA (P172).

## 15 New MEXEC instruction

### (MEXEC P(expression), (directory))

The MEXEC instruction executes the part-program of the indicated directory and it behaves like a canned cycle.

This instruction is executed like the EXEC instruction, but the call is modal. If after this block, any other axis movement is programmed, it will execute the program of the indicated directory after that movement.

If while the modal part-program is selected, a motion block is executed with a number of repetitions (for example X10 N3), the CNC ignores the number of repetitions and executes the movement and the modal part-program only once.

If while a part-program is selected as modal, a block containing the MEXEC instruction is executed from the main program, the current part-program stops being modal and the part-program called upon with MEXEC will then become modal.

If within the modal part-program, an attempt is made to execute a block using the MEXEC instruction, it will issue the relevant error message.

1064: The program cannot be executed.

The part-program may be defined with a number or with an expression whose result is a number.

By default, the CNC interprets that the part-program is in the CNC's RAM memory. If it is in another device, it must be so indicated in (directory):

CARDA	in the "Memkey Card".
HD	in the Hard Disk.
DNC1	in a PC connected through serial line 1.
DNC2	in a PC connected through serial line 2.
DNCE	in a PC connected through Ethernet.

### (MDOFF)

The MDOFF instruction indicates that the mode assumed by a subroutine with the MCALL instruction or a part-program with MEXEC ends in that block.

## 16 Accessing the variables of the auxiliary spindle drive from the oscilloscope.

It is possible to access, through the Sercos or Can bus, the variables of the auxiliary spindle drive by identifying the auxiliary spindle with the "AS" prefix followed by the desired variable.

Examples: AS.SV1  
AS.SV2



NEW FEATURES

(SOFT M: 9.1X)

## 17 Manual intervention with additive handwheel

With manual intervention or additive handwheel, it is possible to move the axes manually while a program is being executed. To do this, once this option is activated, use the handwheel to make a movement to be added to the one resulting from the automatic execution. This movement will be applied as if it were another zero offset.

The general handwheel will be used as the additive handwheel. If there is no general handwheel, use the handwheel associated with the axis.

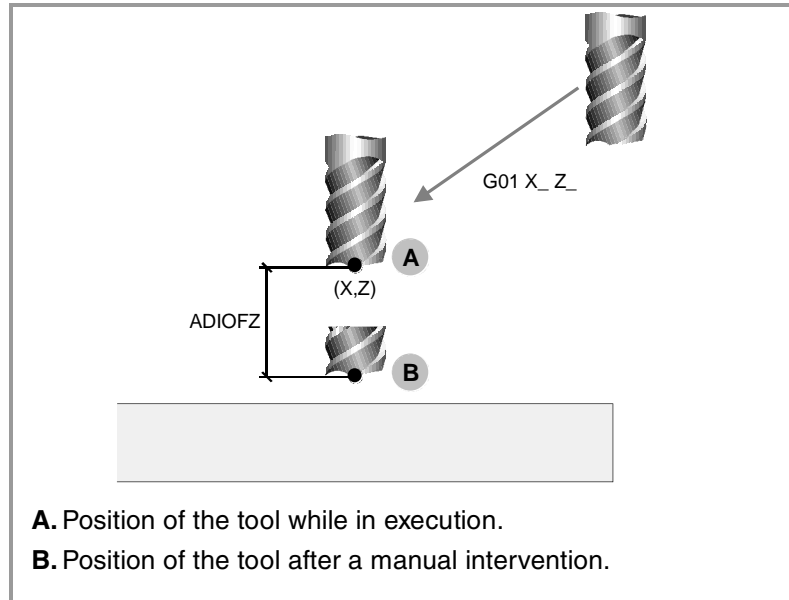

The intervention with an additive handwheel is only possible in execution mode, even while the program is interrupted. However, it is not allowed in the tool inspection mode.

The additive handwheel cannot be enabled while TCP (G48) is active. However, the additive handwheel is enabled for a coordinate transformation G46 (inclined axis) or G49 (incline plane) where the handwheel movements are applied to the machining operation even if they are not shown on the graphics screen.

The offset caused by the additive handwheel stays active after disabling the handwheel and it is reset to zero after a home search. The offset stays active or is reset after an M02 or M30 and after an emergency or a reset depending on the setting of g.m.p. ADIMPG (P172).

### Considerations

- The movement with the additive handwheel on the master axis is also applied to the slave axis when using axes that are gantry, slaved or synchronized by PLC.
- When testing the software limits during block preparation, it checks the theoretical coordinate ignoring the additional movement of the additive handwheel.
- The mirror image by PLC is not applied to the additive handwheel movement.



NEW FEATURES

(SOFT M: 9.1x)

## Variables

The following variable is now available.

**ADIOF(X-C)** Additive zero offset referred to machine reference zero. It is read-only from the CNC, PLC and DNC.

The ADIOF(X-C) values will appear in the zero offset table and they may be displayed on the following-error screens.

## Machine parameter setting

To enable the additive handwheel, set the following machine parameters and consider the following.

- If a.m.p. DWELL (P17) has been set and the axis being moved with the additive handwheel was not already involved in the movement, it activates the ENABLE mark of the axis and waits a period of time indicated in DWELL to check whether the SERVO\*ON signal has been activated or not.
- The acceleration applied to the additive handwheel movement is that of a.m.p. ACCTIME (P18).

**ADIMPG (P176)** This g.m.p. enables the additive handwheel feature. This parameter has 16 bits that will count from left to right. Each bit has a function assigned to it. By default, all bits are set to "0". Setting a bit to "1" activates the corresponding function.

- Bit 1 indicates whether manual intervention is activated or not.
- Bit 2 indicates whether the additive zero offset of the handwheel is canceled or not after an M02 or M30 and after an emergency or reset.
- Bit 3 indicates whether manual intervention is enabled with G51 or not.
- Bit 4 indicates whether the handwheel resolution is set by parameter ADIMPRES (P177) or not.

If not, the resolution is set with the switch of the operator panel. If the switch is not in the handwheel position, it assumes a x1 factor.

**ADIMPRES (P177)** This g.m.p. indicates the resolution of the additive handwheel.

0	0.001mm or 0.0001 inch. (Default value 0)
1	0.01mm or 0.001 inch.
2	0.1mm or 0.01 inch.

**ADIFEED (P84)** This a.m.p. indicates the maximum feedrate allowed due to the additive movement.

By default 1000.0 mm or degrees/min (inch/min).

**DIPLCOF (P110)** This g.m.p. indicates how the coordinates will be displayed and how to access variables POS and TPOS.

- |   |  |
|---|--|
| 0 | When displaying the position of the axes referred to home, it only takes into account the additive offset when displaying the coordinates referred to machine reference zero. The coordinate returned by the POS(X-C) and TPOS(X-C) variables takes into account the additive offset due to the handwheel. |
| 1 | When displaying the position of the axes, it ignores the additive offset due to the handwheel. The coordinate returned by POS(X-C) and TPOS(X-C) ignores that offset.  |
| 2 | When displaying the position of the axes, the CNC takes into account the additive offset set by the handwheel except when showing the Command - Actual - To go coordinates. The coordinate returned by the POS(X-C) and TPOS(X-C) variables takes into account the additive zero offset.                   |



NEW FEATURES

(SOFT M: 9.1X)

## PLC marks

**MANINT(X-C)** This mark activates the offset caused by the additive handwheel. There is one mark per axis.

When a program is in execution and the mark associated with an axis is set to 1, it calculates the movement to be applied to that axis according to the resolution of the handwheel.

Only one additive handwheel may be enabled at a time. If there are more than one mark selected, the first one will be attended to.

## 18 Frequency filters

It is possible to apply frequency filters to the axes as well as to the spindles (main and secondary). There are two types of filters, namely "low passing" or "anti-resonance". To obtain a good machining quality, all the axes interpolating with each other should be defined with the same type of filter and with the same frequency.



*The filters are not applied while moving with an electronic handwheel or a mechanical handwheel or while tracing.*

*It is recommended not to activate these filters on machines carrying out movements against a hard stop.*

### "Low passing" filter

The "Low Passing" filter is used to limit the Jerk by making the movements smoother although it has the drawback that it rounds the corners slightly.

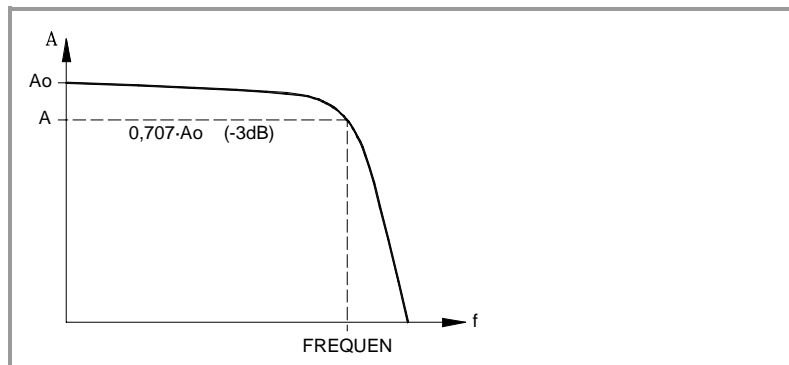

### Anti-resonance filter (notch filter)

The "anti-resonance" (notch) filter must be used when the machine has a resonance frequency to be eliminated.

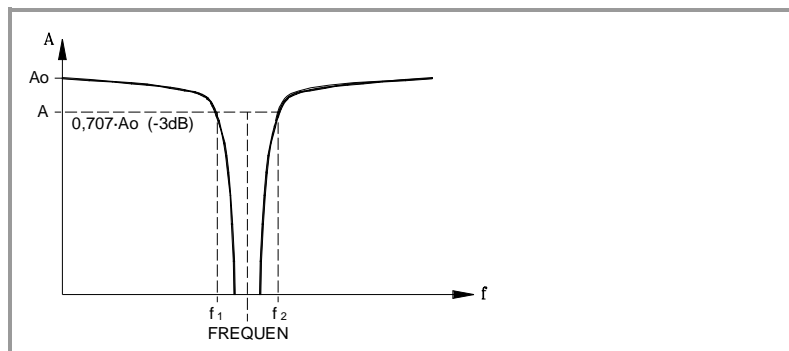

NEW FEATURES

(SOFT M: 9.1x)

## 18.1 Machine parameters for defining the filters

The parameters are updated with a RESET from the machine-parameters screen while the machine is stopped. If an error comes up when designing a filter, that filter will not be applied.

Each axis and spindle has the following machine parameters for configuring the filters.

For the axes	For the spindle
ORDER (P70)	ORDER (P67)
TYPE (P71)	TYPE (P68)
FREQUEN (P72)	FREQUEN (P69)
NORBWID (P73)	NORBWID (P70)
SHARE (P74)	SHARE (P71)

### ORDER (P70)

#### Order of the filter

The down slope is dampened down: The higher the number, the greater the drop.

Possible values:	From 0 to 4
By default:	0 (the filter is not applied).

It is recommended to always set it to 3 when applying a filter. Before setting it to another value, consult with Fagor Automation's technical service.

### TYPE (P71)

#### Type of filter

Two types of filters may be used, namely "low passing" or "anti-resonance".

Possible values:	0: Low passing 1: Anti-resonance (notch filter).
By default:	Low passing.

When defining anti-resonance filters, parameters NORBWIDTH and SHARE must also be set.

### FREQUEN (P72)

#### Break or mid frequency

For the "Low passing" filter, it indicates the break frequency or frequency at which its amplitude drops 3 dB or reaches 70% of the nominal amplitude.

$$-3\text{dB} = 20 \log (A/A_0) \implies A = 0.707 A_0$$

For the "Anti-resonance" (notch) filter, it indicates the mid frequency or frequency at which the resonance reaches its maximum value.

Possible values:	From 0 to 500.0
By default:	30.0



NEW FEATURES

(SOFT M: 9.1X)

**NORBWID (P73)**

**Normal bandwidth**

It is calculated with the following formula. f1 and f2 correspond to the break frequency or frequency at which its amplitude drops 3 dB or reaches 70% of the nominal amplitude.

$$-3dB = 20 \log (A/Ao) \implies A = 0.707 Ao$$

$$NORBWIDTH = \frac{FREQUENCY}{(f_2 - f_1)}$$

The CNC takes it into account when TYPE = Anti-resonance.

Possible values:	From 0 to 100.0
By default:	1.0

**SHARE (P74)**

**% of signal that passes through the filter**

It indicates the signal percentage that passes through the filter. This value must be equivalent to the percentage overshooting of the resonance because it has to make up for it.

The CNC takes it into account when TYPE = Anti-resonance.

Possible values:	From 0 to 100.
By default:	100.

Calculation example for a particular response of the machine.

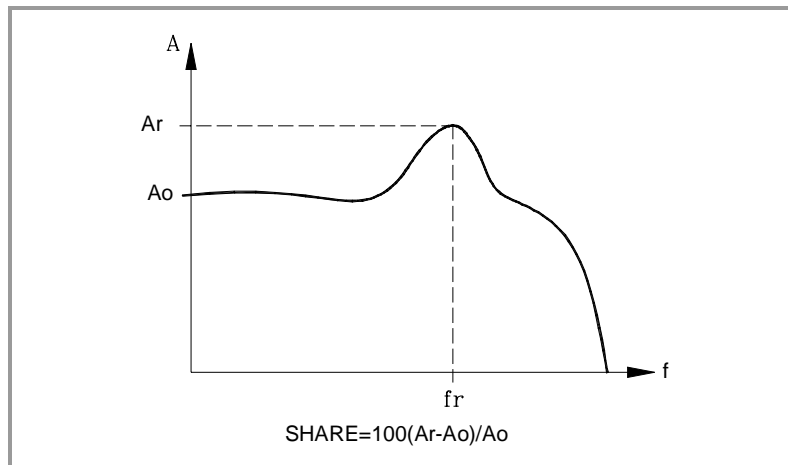

**19 Parameter to set the maximum feedrate in rapid**

**FRAPIDEN (P85)** A.m.p. FRAPIDEN sets the maximum axis feedrate when activating the EXTRAPID mark or when pressing the rapid key in execution or in simulation with motion.

This parameter does not affect the rapid jog which will still have the value of parameter G00FEED.

If set to 0, it assumes the feedrate set by G00FEED. If it is set with a value higher than G00FEED, the feedrate will be limited to this parameter value.



NEW FEATURES

(SOFT M: 9.1x)

## 20 Sercos transmission speed at 8 Mhz and 16 Mhz

Regardless of the baudrate used, always respect the values recommended by g.m.p. SERPOWSE (P121).

**SERSPEED (P120)** This g.m.p. sets the Sercos transmission speed in Mhz.

When using the SERCOS816 board, this parameter may also be assigned the following values:

Value	Transmission speed
8	8 Mhz
16	16 Mhz

With the rest of the boards, the only values admitted are 2 and 4, like until now. The other values will be considered as 4 Mhz except when setting a value of 1, in that case it assumes a speed of 2 Mhz.

The type of board installed may be checked in diagnosis mode, in hardware configuration. The new board will be identified as "SERCOS816".

With previous software versions, the transmission speed of this board will be limited to 4 Mhz.



*Sercos communication at 8 and 16 Mhz requires servo drive version V6.05.*

## 21 New range of G functions

The range of available G functions has been increased to 319.

## 22 DNC communication status

**DNCSTA** It may be used to know from the PLC the status of the RS transmission even when not having the DNC option.

This parameter has 16 bits that will count from left to right. There is one bit for each DNC . The bit will be set to "1" when transmission is in progress:

Bit	Meaning
1	Transmission in progress through DNC1.
8	Transmission in progress through DNC2.

## 23 The motionless simulation ignores G4

The dwells set in a program through G4 K are ignored when simulating without movement.

The G4 K blocks will not be executed when simulating the theoretical path, the G functions or the G, M, S and T functions.



## 24 Status of the timer programmed with G4

<b>TIMEG</b>	It may be used to display the timing status of the timer programmed with G4 K in the CNC channel.  This variable, returns the time remaining to end the timing block in seconds.  It is read-only from the CNC, PLC and DNC.
--------------	--

## 25 Maintain the last F selected in simulation

While in simulation mode, it is possible to select the feedrate of the axes for simulation. From now on, it will keep the last F selected.

## 26 Parameters accessible from the oscilloscope or OEM program

If parameter REFVALUE, REFDIRREC, FLIMIT or SLIMIT is written from an OEM program or from the oscilloscope, it will be validated automatically.

Parameters REFVALUE, REFDIRREC and SLIMIT are assumed immediately whereas FLIMIT will be assumed at the beginning of the next block.

## 27 Controlled braking of spindle and axes via Sercos in case of an emergency at the CNC

When an emergency occurs at the CNC, the SPENA\* signals of the axes and the spindle are disabled and the drive brakes using the emergency ramps.

## 28 New coordinate variables APOS and ATPOS

These variables are equivalent to variables POS(X-C) and TPOS(X-C) but they always show the value in part coordinates.

<b>POS(X-C)</b>	Machine coordinates. Real of the tool base.
<b>TPOS(X-C)</b>	Machine coordinates. Theoretical of the tool base.
<b>APOS(X-C)</b>	Part coordinates. Real of the tool base.
<b>ATPOS(X-C)</b>	Part coordinates. Theoretical of the tool base.



NEW FEATURES

(SOFT M: 9.1X)



## 1 Hirth axis pitch may be set in degrees via parameters

**HPITCH (P89)** On Hirth axes, it indicates its pitch in degrees. It admits values other than 1° and decimal values. The HPITCH value must be such that the remainder when dividing 360/HPITCH must be zero.

When set to 0, it assumes a pitch value of 1°.

Possible values:	From 0 to 99999.9999 degrees.
By default:	1.0000 (1°)

If the HPITCH value has decimals, the screen displays the coordinates with decimals.

Any stop or continuous jog movement will stop the axis in coordinates multiple of HPITCH. The incremental jog movements will be similar to the ones carried out with a 1 degree pitch.

- For incremental switch positions of 1, 10, 100 or 1000, it will move 1 step.
- For an incremental switch position 10000, the movement will be multiple of the closest pitch to 10°, under 10°. If the pitch value is greater than 10°, it will move a single step.

Even if the position of a Hirth axis does not coincide with its Hirth pitch, it may be moved to a position that coincides with the pitch in both automatic and jog modes. An error message will be issued if the position to move the axis does not coincide with the pitch. In any case, it is possible to move any other axis in both automatic and jog modes.

## 2 Rollover positioning axes. Movements in G53 via the shortest way

**AXISDEF (P90)** Its bits indicate how the movements are set.  
(1)xxx xxxx xxxx xxxx

Bit	Meaning
1	Movement in G53 for rollover rotary axes.

The leftmost bit indicates the setting of G53 movements for rollover positioning rotary axes, without travel limits.

AXISTYPE = 3 or 4      ROLLOVER = YES  
LIMIT+ = 0              LIMIT- = 0

When set to "1", G53 movements are carried out along the shortest path. When set to "0", it works like before. When several settings, the G53 movement may rotate several complete turns.



NEW FEATURES

(SOFT M: 9.1x)

### 3 New "Sercos II" transmission board

#### 3.1 New Sercos power table

**SERPOUSE (P121)** It sets the Sercos power or the intensity of the light going through the optical fiber. Its value depends on the total length of the cable being used. Set it with the same value used by the drives.

Possible values:	From 1 to 6.
By default:	4.

Assigning other values, for example a value 4 for a length of 3 m, may cause communication errors due to signal distortion in the optical fiber.

Recommended values (Sercos II board).

1	For lengths under 15 meters.
2	For lengths between 15 and 30 meters.
3	For lengths between 30 and 45 meters.
4	For lengths over 45 meters.

#### 3.2 Set the transmission delay at the bus for transmissions at 8 Mhz and 16 Mhz

**SERCDEL1 (P178)** It may be used to set the Sercos transmission delay. The default delay is 400  $\mu$ s and this parameter may be used to set a delay of 600  $\mu$ s.

Possible values:	0 / 400 / 600 microseconds.
By default:	0 (equivalent to a delay of 400 $\mu$ s.)

Setting a longer delay at the bus permits increasing the amount of data going through the fast channel of the bus. This may be necessary, for example, when having set many PLC parameters (SRR700 to SRR739) that define the fast channel or when accessing variables of several drives from the oscilloscope.

In any case, if the CNC detects a limit situation in the bus capacity, it will show a message suggesting to increase this parameter.

When changing the parameter value from 0 (400) to 600 on a machine using the fine adjustment, i.e. with "zero following error", we recommend to slightly increase the value of the DERGAIN parameter (when ACFGAIN = YES) to compensate for the 200 microsecond delay.



*The 0 value (400 $\mu$ s) is compatible with all versions except V9.11, V10.11, V9.12 and V10.12. When updating the software from one of these versions to a V9.13 or V10.13, the value of SERCDEL1 must be set to 600.*

**SERCDEL2 (P179)** Not being used.



